

CBSE

Solved Paper 2023

Science

Delhi/Outside Delhi

Time : 2:30 Hours

CLASS-X

Max. Marks : 80

General Instructions:

Read the following instructions very carefully and follow them :

1. This question paper consists of 39 questions. All questions are compulsory.
2. Question paper is divided into FIVE sections - Section A, B, C, D and E.
3. In Section - A question number 1 to 20 are multiple choice questions (MCQs) carrying 1 mark each.
4. In Section - B question number 21 to 26 are very short answer (VSA) type questions carrying 2 marks each. Answer to these questions should be in the range of 30 to 50 words.
5. In Section - C question number 27 to 33 are short answer (SA) type questions carrying 3 marks each. Answer to these questions should be in the range of 50 to 80 words.
6. In Section - D question number 34 to 36 are long answer (LA) type questions carrying 5 marks each. Answer to these questions should be in the range of 80 to 120 words.
7. In Section - E question number 37 to 39 are of 3 source based/case based units of assessment carrying 4 marks each with sub-parts.
8. There is no overall choice. However, an internal choice has been provided in some sections.

Delhi Set-1

31/4/1

SECTION — A

(Multiple Choice Questions)

1. When sodium bicarbonate reacts with dilute hydrochloric acid, the gas evolved is: 1
 - (a) Hydrogen; it gives pop sound with burning match stick.
 - (b) Hydrogen; it turns lime water milky.
 - (c) Carbon dioxide; it turns lime water milky.
 - (d) Carbon dioxide; it blows off a burning match stick with a pop sound.
2. When aqueous solutions of potassium iodide and lead nitrate are mixed, an insoluble substance separates out. The chemical equation for the reaction involved is: 1
 - (a) $KI + PbNO_3 \longrightarrow PbI + KNO_3$
 - (b) $2KI + Pb(NO_3)_2 \longrightarrow PbI_2 + 2KNO_3$
 - (c) $KI + Pb(NO_3)_2 \longrightarrow PbI + KNO_3$
 - (d) $KI + PbNO_3 \longrightarrow PbI_2 + KNO_3$
3. A metal ribbon 'X' burns in oxygen with a dazzling white flame forming a white ash 'Y'. The correct description of X, Y and the type of reaction is: 1
 - (a) X = Ca; Y = CaO ; Type of reaction = Decomposition
 - (b) X = Mg; Y = MgO ; Type of reaction = Combination
 - (c) X = Al; Y = Al₂O₃ ; Type of reaction = Thermal decomposition
 - (d) X = Zn; Y = ZnO ; Type of reaction = Endothermic
4. Acid present in tomato is: 1
 - (a) Methanoic acid
 - (b) Acetic acid
 - (c) Lactic acid
 - (d) Oxalic acid

5. Sodium hydroxide is termed an alkali while Ferric hydroxide is not because: 1
- Sodium hydroxide is a strong base, while Ferric hydroxide is a weak base.
 - Sodium hydroxide is a base which is soluble in water while Ferric hydroxide is also a base but it is not soluble in water.
 - Sodium hydroxide is a strong base while Ferric hydroxide is a strong acid.
 - Sodium hydroxide and Ferric hydroxide both are strong base but the solubility of Sodium hydroxide in water is comparatively higher than that of Ferric hydroxide.

6. The name of the salt used to remove permanent hardness of water is: 1
- Sodium hydrogen carbonate (NaHCO_3)
 - Sodium chloride (NaCl)
 - Sodium carbonate decahydrate ($\text{Na}_2\text{CO}_3 \cdot 10\text{H}_2\text{O}$)
 - Calcium sulphate hemihydrate ($\text{CaSO}_4 \cdot \frac{1}{2}\text{H}_2\text{O}$)

7. The electron dot structure of chlorine molecule is: 1

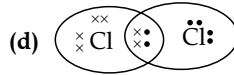
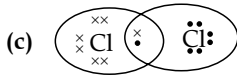
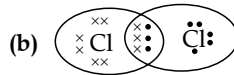
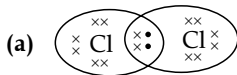

8. Observe the following diagram and identify the process and its significance from the following options: 1

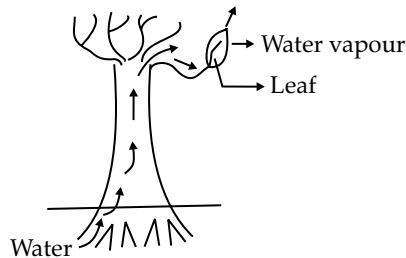

- Evaporation: maintains water contents in leaf cells.
 - Transpiration: creates a suction force which pulls water inside the plant.
 - Excretion: helps in excreting out waste water from the plant.
 - Translocation: helps in transporting materials from one cell to another.
9. Opening and closing of stomata is due to: 1
- High pressure of gases inside the cells.
 - Movement of water in and out of the guard cells.
 - Stimulus of light in the guard cells.
 - Diffusion of CO_2 in and out of the guard cells.
10. A cross between pea plant with white flowers (vv) and pea plant with violet flowers (VV) resulted in F_2 progeny in which ratio of violet (VV) and white (vv) flowers will be: 1
- 1 : 1
 - 2 : 1
 - 3 : 1
 - 1 : 3

11. In plants the role of cytokinin is: 1

- Promote cell division
- Wilting of leaves
- Promote the opening of stomatal pore
- Help in the growth of stem

12. The number of chromosomes in parents and offsprings of a particular species undergoing sexual reproduction remain constant due to: 1

- doubling of chromosomes after zygote formation.
- halving of chromosomes after zygote formation.

- (c) doubling of chromosomes before gamete formation.
 (d) halving of chromosomes at the time of gamete formation.
13. Two LED bulbs of 12W and 6W are connected in series. If the current through 12W bulb is 0.06A the current through 6W bulb will be: 1
- (a) 0.04A (b) 0.06A
 (c) 0.08A (d) 0.12A
14. The correct pattern of magnetic field lines of the field produced by a current carrying circular loop is : 1

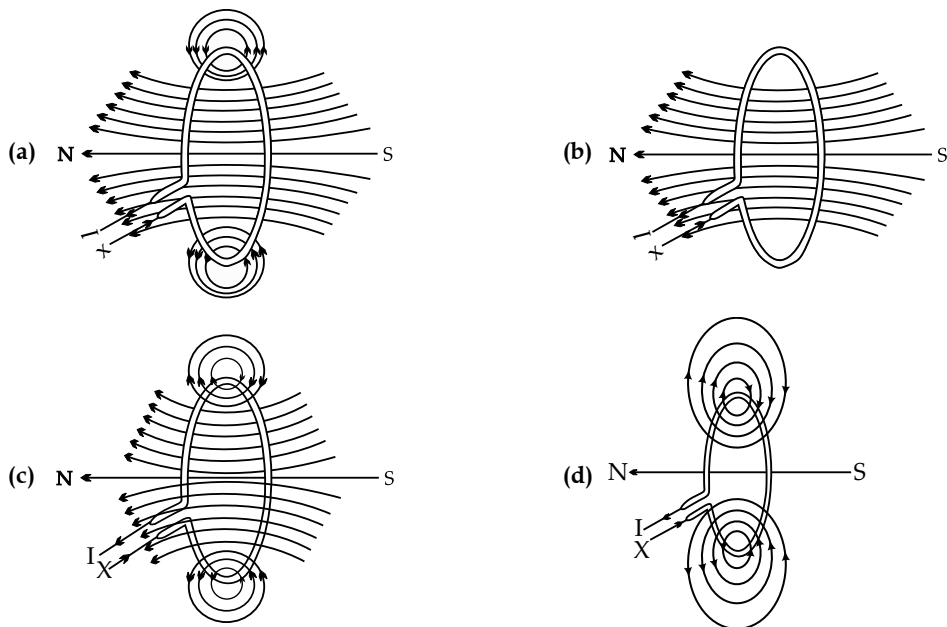

15. The resistance of a resistor is reduced to half of its initial value. If other parameters of the electrical circuit remain unaltered, the amount of heat produced in the resistor will become: 1
- (a) four times (b) two times
 (c) half (d) one fourth
16. An alpha particle enters a uniform magnetic field as shown. The direction of force experienced by the alpha particle is: 1

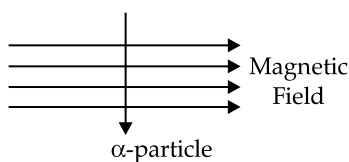

- (a) towards right (b) towards left
 (c) into the page (d) out of the page

Q. No. 17 to 20 are Assertion – Reasoning based questions.

These consist of two statements - Assertion (A) and Reason (R). Answer these questions selecting the appropriate option given below.

- (a) Both (A) and (R) are true and (R) is the correct explanation of (A).
 (b) Both (A) and (R) are true but (R) is not the correct explanation of (A).
 (c) (A) is true but (R) is false.
 (d) (A) is false but (R) is true.
17. **Assertion (A):** Reaction of quicklime with water is an exothermic reaction. 1
Reason (R): Quicklime reacts vigorously with water releasing a large amount of heat.

18. **Assertion (A):** In humans, if gene (B) is responsible for black eyes and gene (b) is responsible for brown eyes, then the colour of eyes of the progeny having gene combination Bb, bb or BB will be black only.
Reason (R): The black colour of the eyes is a dominant trait. 1
19. **Assertion (A):** The inner walls of the small intestine have finger like projections called villi which are rich in blood.
Reason (R): These villi have a large surface area to help the small intestine in completing the digestion of food. 1
20. **Assertion (A):** A current carrying straight conductor experiences a force when placed perpendicular to the direction of magnetic field.
Reason (R): The net charge on a current carrying conductor is always zero. 1

SECTION — B

(Very Short Answer Questions)

21. (A) A student took a small amount of copper oxide in a conical flask and added dilute hydrochloric acid to it with constant stirring. He observed a change in colour of the solution. 2
- (i) Write the name of the compound formed and its colour.
- (ii) Write a balanced chemical equation for the reaction involved.

OR

- (B) The industrial process used for the manufacture of caustic soda involves electrolysis of an aqueous solution of compound 'X'. In this process, two gases 'Y' and 'Z' are liberated. 'Y' is liberated at cathode and 'Z', which is liberated at anode, on treatment with dry slaked lime forms a compound 'B'. Name X, Y, Z and B. 2
22. (A) Name the part of brain which is responsible for the following actions: 2
- (i) Maintaining posture and balance
- (ii) Beating of heart
- (iii) Thinking
- (iv) Blood pressure

OR

- (B) Where are auxins synthesized in a plant? Which organ of the plant shows: 2
- (i) Positive phototropism
- (ii) Negative geotropism
- (iii) Positive hydrotropism
23. Write one specific function each of the following organs in relation with excretion in human beings: 2
- (i) Renal Artery
- (ii) Urethra
- (iii) Glomerulus
- (iv) Tubular part of nephron
24. Two green plants are kept separately in oxygen free containers, one in the dark and other in sunlight. It was observed that plant kept in dark could not survive longer. Give reason for this observation. 2
25. (A) Observe the following diagram and answer the questions following it: 2

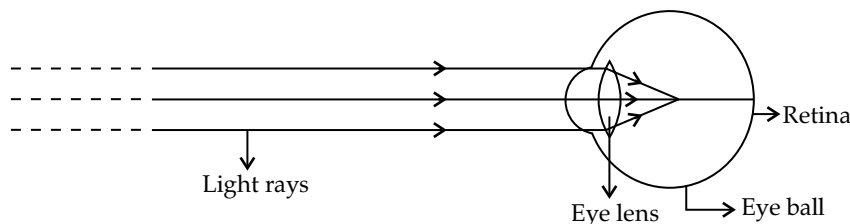

- (i) Identify the defect of vision shown.
- (ii) List its two causes.
- (iii) Name the type of lens used for the correction of this defect.

OR

- (B) The colour of clear sky from the earth appears blue but from the space it appears black. Why? 2
26. Use of several pesticides which results in excessive accumulation of pesticides in rivers or ponds, is a matter of deep concern. Justify this statement. 2

SECTION — C

(Short Answer Questions)

27. (i) While electrolysing water before passing the current some drops of an acid are added. Why? Name the gases liberated at cathode and anode. Write the relationship between the volume of gas collected at anode and the volume of gas collected at cathode. 3
- (ii) What is observed when silver chloride is exposed to sunlight? Give the type of reaction involved.
28. (i) Suggest a safe procedure of diluting a strong concentrated acid. 3
- (ii) Name the salt formed when sulphuric acid is added to sodium hydroxide and write its pH.
- (iii) Dry HCl gas does not change the colour of dry blue litmus paper. Why?
29. (A) (i) How does *Paramecium* obtain its food? 3
- (ii) List the role of each of the following in our digestive system:
- | | |
|-------------------------------|----------------------|
| (a) Hydrochloric acid | (b) Trypsin |
| (c) Muscular walls of stomach | (d) Salivary amylase |

OR

- (B) (i) What is double circulation? 3
- (ii) Why is the separation of the right side and the left side of the heart useful? How does it help birds and mammals?
30. (A) Define the following terms in the context of a diverging mirror: 3
- (i) Principal focus
- (ii) Focal length
- Draw a labelled ray diagram to illustrate your answer.

OR

- (B) An object of height 10 cm is placed 25 cm away from the optical centre of a converging lens of focal length 15 cm. Calculate the image-distance and height of the image formed. 3
31. The power of a lens is +4D. Find the focal length of this lens. An object is placed at a distance of 50 cm from the optical centre of this lens. State the nature and magnification of the image formed by the lens and also draw a ray diagram to justify your answer. 3
32. (A) (i) Why is an alternating current (A.C.) considered to be advantageous over direct current (D.C.) for the long distance transmission of electric power? 3
- (ii) How is the type of current used in household supply different from the one given by a battery of dry cells?
- (iii) How does an electric fuse prevent the electric circuit and the appliances from a possible damage due to short circuiting or overloading.

OR

- (B) For the current carrying solenoid as shown, draw magnetic field lines and give reason to explain that out of the three points A, B and C, at which point the field strength is maximum and at which point it is minimum? 3

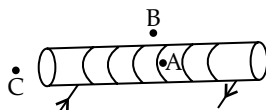

33. Write one difference between biodegradable and non-biodegradable wastes. List two impacts of each type of the accumulated waste on environment if not disposed off properly. 3

SECTION — D

(Long Answer Questions)

34. (A) (i) Draw the structure of the following components? 5
 (a) Butanoic acid (b) Chloropentane
 (ii) How are structure (i) and structure (ii) given below related to one another? Give reason to justify your answer

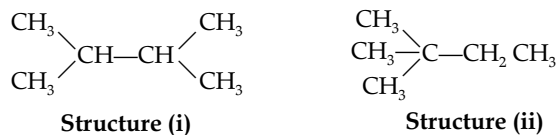

Draw one more possible structure for above case.

- (iii) Differentiate between saturated and unsaturated compounds on the basis of their general formula.

OR

- (B) (i) What happens when a small piece of sodium is dropped on ethanol? Write the equation for this reaction.
 (ii) Why is glacial acetic acid called so? 5
 (iii) What happens when ethanol is heated at 443 K in the presence of conc. H_2SO_4 ? Write the role of Conc. H_2SO_4 in this case.
 (iv) Write an equation showing saponification.
35. (i) Name and explain the two modes of asexual reproduction observed in *hydra*. 5
 (ii) What is vegetative propagation? List two advantages of using this technique.
36. (i) How is electric current related to the potential difference across the terminals of a conductor? 5
 Draw a labelled circuit diagram to verify this relationship.
 (ii) Why should an ammeter have low resistance?
 (iii) Two V - I graphs A and B for series and parallel combinations of two resistors are as shown. Giving reason state which graph shows (a) series, (b) parallel combination of the resistors.

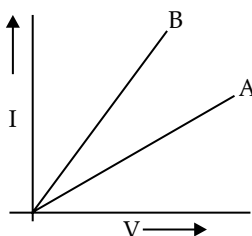

SECTION — E

(Source Based/Case Based Questions)

37. The melting points and boiling points of some ionic compounds are given below: 4

Compound	Melting Point (K)	Boiling Point (K)
NaCl	1074	1686
LiCl	887	1600
CaCl_2	1045	1900
CaO	2850	3120
MgCl_2	981	1685

These compounds are termed ionic because they are formed by the transfer of electrons from a metal to a non-metal. The electron transfer in such compounds is controlled by the electronic configuration of the elements involved. Every element tends to attain a completely filled valence shell of its nearest noble gas or a stable octet.

- (i) Show the electron transfer in the formation of magnesium chloride. 1
 (ii) List two properties of ionic compounds other than their high melting and boiling points. 1

- (iii) (A) While forming an ionic compound say sodium chloride how does sodium atom attain its stable configuration ? 2

OR

- (iv) (B) Give reasons: 2
- (i) Why do ionic compounds in the solid state not conduct electricity?
- (ii) What happens at the cathode when electricity is passed through an aqueous solution of sodium chloride ?

38. The most obvious outcome of the reproductive process is the generation of individuals of similar design, but in sexual reproduction they may not be exactly alike. The resemblances as well as differences are marked. The rules of heredity determine the process by which traits and characteristics are reliably inherited. Many experiments have been done to study the rules of inheritance. 4

- (i) Why an offspring of human being is not a true copy of his parents in sexual reproduction? 1
- (ii) While performing experiments on inheritance in plants, what is the difference between F_1 and F_2 generation? 1
- (iii) (A) Why do we say that variations are useful for the survival of a species over time ? 2

OR

- (iii) (B) Study Mendel's cross between two plants with a pair of contrasting characters. 2
- | | | |
|--------------|---|----------------|
| RRYY | × | rryy |
| Round Yellow | | Wrinkled Green |
- He observed 4 types of combinations in F_2 generation. Which of these were new combinations? Why do new features which are not present in the parents, appear in F_2 generation ?

39. The ability of a medium to refract light is expressed in terms of its optical density. Optical density has a definite connotation. It is not the same as mass density. On comparing two media, the one with the large refractive index is optically denser medium than the other. The other medium with a lower refractive index is optically rarer. Also the speed of light through a given medium is inversely proportional to its optical density. 4

- (i) Determine the speed of light in diamond if the refractive index of diamond with respect to vacuum is 2.42. Speed of light in vacuum is 3×10^8 m/s. 1
- (ii) Refractive indices of glass, water and carbon disulphide are 1.5, 1.33 and 1.62 respectively. If a ray of light is incident in these media at the same angle (say θ), then write the increasing order of the angle of refraction in these media. 1
- (iii) (A) The speed of light in glass is 2×10^8 m/s and in water is 2.25×10^8 m/s. 2
- (a) Which one of the two is optically denser and why ?
- (b) A ray of light is incident normally at the water-glass interface when it enters a thick glass container filled with water. What will happen to the path of the ray after entering the glass? Give reason.

OR

- (iii) (B) The absolute refractive indices of water and glass are $4/3$ and $3/2$ respectively. If the speed of light in glass is 2×10^8 m/s, find the speed of light in (i) vacuum and (ii) water. 2

Delhi Set-2

31/4/2

Note: Except these, all other questions are from Delhi Set - 1

SECTION — A

(Multiple Choice Questions)

9. During adolescence, reproductive phase starts and: 1
- (a) general growth rate begins to slow down (b) height becomes less
- (c) the body weight is reduced (d) hair growth decreases
10. Which pair of sex chromosome will determine a male ? 1
- (a) XO (b) XX
- (c) XY (d) YY

11. One of the events that does not occur during photosynthesis is: 1
 (a) Chlorophyll absorbs solar energy. (b) Carbon dioxide is released during the process.
 (c) Oxygen is released during the process. (d) Carbon dioxide is absorbed during the process.
16. Two LED bulbs of 10W and 5W are connected in series. If the current flowing through 5W bulb is 0.005A, the current flowing through 10W bulb is: 1
 (a) 0.02A (b) 0.01A
 (c) 0.005A (d) 0.0025A

SECTION — B

(Very Short Answer Questions)

21. (i) State the essential function performed by ozone at the higher levels of the atmosphere. 2
 (ii) Why was there a sharp drop in the amount of ozone in the atmosphere in 1980's?
24. Give two reasons why bile juice is considered to be an important secretion of liver in the process of digestion? 2
25. Name the hormone secreted in scary situations by animals. Write any three responses which enable the animal body to deal with it. 2

SECTION — C

(Short Answer Questions)

29. List two differences in the characteristic properties of the virtual images formed by the two types of spherical lenses (concave and convex). How are these characteristics of the two lenses used in the correction of the two common defects of vision namely myopia and hypermetropia? 3
30. (A) An object is kept at a distance of 1m from a lens of power +2D: 3
 (i) Identify the type of lens.
 (ii) Calculate its focal length and distance of the image formed.
32. (i) Why is acidified water considered to be a good conductor of electricity? 3
 (ii) Write a chemical equation showing the ionic products formed on dissolving potassium hydroxide in water.
 (iii) Care must be taken while diluting concentrated nitric acid with water. Why?

SECTION — D

(Long Answer Questions)

36. (A) (i) It is observed that covalent compounds are bad conductors of electricity. Give reason. 5
 (ii) Carbon can neither form C^{4-} cation nor C^{4+} anion. Why?
 (iii) Draw electron dot structure of Ethanol.
 (iv) Identify hetero atom(s) in the following compounds:
 (a) $\text{CH}_3\text{CH}_2-\overset{\text{O}}{\parallel}{\text{C}}-\text{CH}_3$
 (b) $\text{CH}_3\text{CH}_2\text{Cl}$

OR

- (B) (i) What are soaps? Explain the mechanism of cleansing action of soap with the help of a labelled diagram. 5
 (ii) Detergents are better than soaps. Justify.

Delhi Set-3

31/4/3

Note: Except these, all other questions are from Delhi Set 1 and 2

SECTION — A

(Multiple Choice Questions)

9. Water in the root enters due to: 1
 (a) the function of the root to absorb water
 (b) difference in the concentration of ions between the root and the soil.
 (c) excess water present in the soil
 (d) diffusion of water in the roots
10. Which one of the given statements is incorrect: 1
 (a) DNA has the complete information for a particular characteristic

- (b) DNA is the molecule responsible for the inheritance of characteristic from parents to offsprings
 (c) Change in information will produce a different protein
 (d) Characteristics will remain the same even if protein changes
11. Sensory nerve of a reflex arc carries information from the receptor cells to the: 1
- (a) spinal cord (b) brain
 (c) muscles of the effector organ (d) bones of the receptor organ

SECTION — B

(Very Short Answer Questions)

21. Name a plant hormone responsible for ending of a shoot of a plant when it is exposed to unidirectional light. How does it promote phototropism? 2
24. What is the other name of 'tissue fluid'? Write its two functions. 2
25. "Although gardens are created by man but they are considered to be an ecosystem." Justify this statement. 2

SECTION — C

(Short Answer Questions)

27. Consider the following salts: 3
- (i) YCl (ii) NH₄X (iii) ZCO₃
- (a) What would be the pH of the salt solution if in YCl, Y is sodium? Give Reason for your answer?
 (b) If in salt NH₄X, X is nitrate, then its solution will give what colour with universal indicator? Why?
 (c) What would be the change in colour in blue litmus solution if ZCO₃ is added to it and Z is potassium?
33. (A) Define the term dispersion of white light. State the colour which bends (i) the most, (ii) the least while passing through a glass prism. Draw a diagram to show the dispersion of white light. 3

OR

- (B) What is a rainbow? Draw a labelled diagram to show its formation. 3

SECTION — D

(Long Answer Questions)

36. (A) Write the chemical equation for the following: 5
- (i) Combustion of methane (ii) Oxidation of ethanol
 (iii) Hydrogenation of ethene (iv) Esterification Reaction
 (v) Saponification Reaction

OR

- (B) (i) Draw two structural isomers of butane 5
 (ii) Draw the structures of propanol and propanone
 (iii) Name the third homologue of:
 (a) alcohols (b) aldehydes

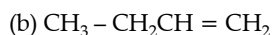
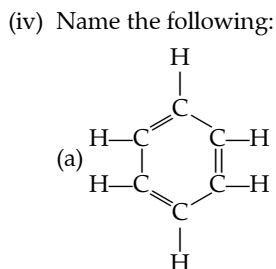

- (v) Show the covalent bond formation in nitrogen molecule.

SECTION — A

Select and write one most appropriate option out of the four options given for each of the questions 1-20.

1. Metal oxides generally react with acids, but few oxides of metal also react with bases. Such metallic oxides are : 1

- I. MgO
II. ZnO
III. Al₂O₃
IV. CaO

- (a) I and II (b) II and III
(c) III and IV (d) I and IV

2. Few drops of aqueous solution of ammonium chloride are put on a universal indicator paper. The paper turns pink. 1

Study the following table and choose the correct option.

Nature	Ammonium chloride is a salt of...	Range of pH
(a) acidic	weak acid and strong base	less than 7
(b) basic	weak acid and strong base	more than 7
(c) acidic	strong acid and weak base	less than 7
(d) basic	strong acid and strong base	7

3. Select the appropriate state symbols of the products given as X and Y in the following chemical equation by choosing the correct option from table given below: 1

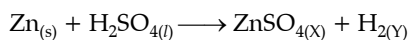

	(X)	(Y)
(a)	(s)	(l)
(b)	(aq)	(s)
(c)	(aq)	(g)
(d)	(g)	(aq)

4. Two salts X and Y are dissolved in water separately. When phenolphthalein is added to these two solutions the solution X turns pink and the solution Y does not show any change in colour, therefore X and Y are: 1

	(X)	(Y)
(a)	Na ₂ CO ₃	NH ₄ Cl
(b)	Na ₂ SO ₄	NaHCO ₃
(c)	NH ₄ Cl	Na ₂ SO ₄
(d)	NaNO ₃	Na ₂ SO ₄

5. In the given diagram of a closed stomata: (1), (2), (3) and (4) respectively are: 1

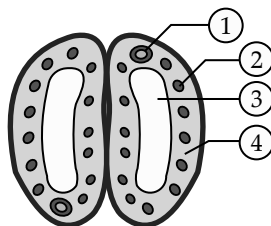

- (a) nucleus, chloroplast, guard cell, vacuole (b) nucleus, chloroplast, vacuole, guard cell
(c) chloroplast, nucleus, vacuole, guard cell (d) vacuole, guard cell, nucleus, chloroplast

6. Walking in a straight line and riding a bicycle are the activities which are possible due to a part of the brain. Choose the correct location and name of this part from the given table: 1

	Part of the Brain	Name
(a)	Fore brain	Cerebrum
(b)	Mid brain	Hypothalamus
(c)	Hind brain	Cerebellum
(d)	Hind brain	Medulla

7. A student wants to obtain an erect image of an object using a concave mirror of 10 cm focal length. What will be the distance of the object from mirror? 1

- (a) Less than 10 cm (b) 10 cm
 (c) between 10 cm and 20 cm (d) more than 20 cm

8. Bronze is an alloy of: 1

- (a) Copper and Zinc (b) Aluminium and Tin
 (c) Copper, Tin and Zinc (d) Copper and Tin

9. In an experiment with pea plants, a pure tall plant (TT) is crossed with a pure short plant (tt). The ratio of pure tall plant to pure short plants in F₂ generation will be: 1

- (a) 1 : 3 (b) 3 : 1
 (c) 1 : 1 (d) 2 : 1

10. Study the given figure of a Food web and identify the primary consumer in the food web: 1

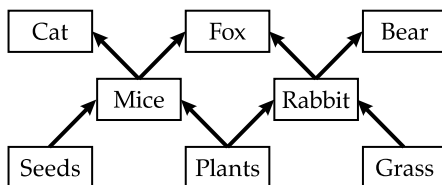

- (a) Mice and Bear (b) Rabbit and Cat
 (c) Rabbit and Fox (d) Mice and Rabbit

11. Choose the correct order of the stages of binary fission in *Leishmania*. 1

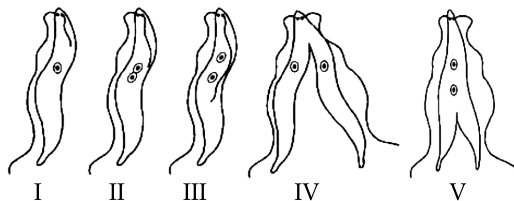

- (a) I, II, III, IV, V (b) I, III, II, V, IV
 (c) I, III, V, II, IV (d) I, II, III, V, IV

12. Consider the following chemical equation I and II. 1

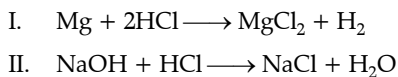

The correct statement about these equations is:

- (a) 'I' is a displacement reaction and 'II' is a decomposition reaction.
 (b) 'I' is a displacement reaction and 'II' is double displacement reaction.

- (c) Both 'I' and 'II' are displacement reactions.
 (d) Both 'T' and 'II' are double-displacement reactions.

13. In the following diagram showing dispersion of white light by a glass prism, the colours 'P' and 'Q' respectively are - 1

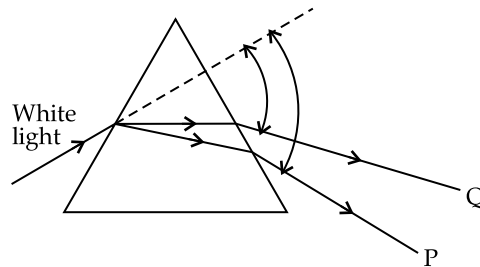

- (a) Red and Violet (b) Violet and Red
 (c) Red and Blue (d) Orange and Green
14. Consider the following three flower namely X, Y and Z. Which flower (s) would develop into a fruit? 1

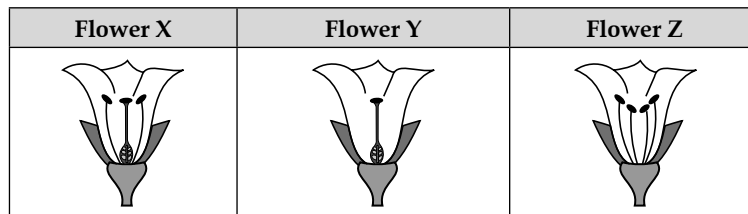

- (a) 'X' only (b) 'Z' only
 (c) 'X' and 'Y' only (d) 'Y' and 'Z'
15. The magnetic field inside a long straight current carrying solenoid: 1
- (a) is zero (b) decreases as we move towards its end.
 (c) increases as we move towards its end (d) is same at all points.
16. In human eye the part which allows light to enter into the eye is: 1
- (a) Retina (b) Pupil
 (c) Eye lens (d) Cornea

Q. No. 17 to 20 are Assertion Reasoning based question:

These consists of two statements—Assertion (A) and Reason (R). Answer these questions selecting the appropriate option given below:

- (a) Both Assertion (A) and Reason (R) are true and Reason (R) is the correct explanation (A)
 (b) Both Assertion (A) and Reason (R) are true but Reason (R) is not the correct explanation of (A).
 (c) Assertion (A) is true, but Reason (R) is false.
 (d) Assertion (A) is false, but Reason (R) is true.
17. **Assertion (A):** It is advised that while diluting an acid one should add water to acid and not acid to water keeping the solution continuously stirred. 1
Reason (R): The process of dissolving an acid into water is highly exothermic.
18. **Assertion (A):** The energy which passes to the herbivores does not come back to autotrophs. 1
Reason (R): The flow of energy in a food chain is unidirectional.
19. **Assertion (A):** *Amoeba* takes in food using finger like extensions of the cell surface. 1
Reason (R): In all unicellular organisms. the food is taken in by the entire cell surface.
20. **Assertion (A):** Melting point and boiling point of ethanol are lower than that of sodium chloride. 1
Reason (R): The forces of attraction between the molecules of ionic compounds are very strong

SECTION — B**Q. No 21 to 26 are Very Short Answer Questions.**

21. State whether the given chemical reaction is a redox reaction or not. 2

Justify: your answer



22. (a) List two differences between the movement of leaves of a sensitive plant and the movement of a shoot towards light. 2

OR

- (b) What happens at synapse between two neurons? State briefly. 2

23. Give the name of the enzyme present in the fluid in our mouth cavity.

State the gland which produces it. What would happen to the digestion process if this gland stops secreting this enzyme? 2

24. Let the resistance of an electrical device remain constant, while the potential difference across its two ends decreases to one fourth of its initial value. What change will occur in the current through it? State the law which helps us in solving the above stated question. 2

25. A light ray enters from medium A to medium B as shown in the figure.

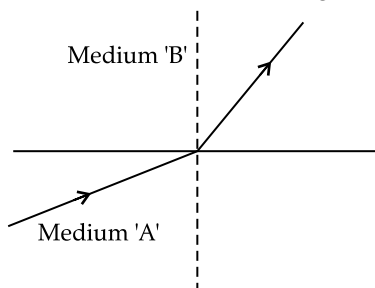

- (a) Which one of the two media is denser w.r.t. other medium? Justify your answer. 1

- (b) If the speed of light in medium A is V_A and V_B is V_B , what is the refractive index of B with respect to A? 1

OR

- (a) A ray of light skirting from diamond is incident on the interface separating diamond and water. Draw a labeled ray diagram to show the refraction of light in this case. 1

- (b) Absolute refractive indices of diamond and water are 2.42 and 1.33 respectively. Find the value of refractive index of water w.r.t. diamond. 1

26. State the rule to determine the direction of (a) magnetic field produced around a straight conductor carrying current and (b) force experienced by a current carrying straight conductor placed in a magnetic field which is perpendicular to it. 2

SECTION — C**Q.No. 27 to 33 are Short Answer Questions.**

27. Explain the process of transport of oxygenated and deoxygenated blood in a human body. 3

28. (a) A substance X is used as a building material and is insoluble in water. When it reacts with dil. HCl, it produces a gas which turns lime water milky. 3

(i) Write the chemical name and formula of 'X'.

(ii) Write chemical equations for the chemical reactions involved in the above statements.

OR

- (b) A metal 'M' on reacting with dilute acid liberates a gas 'G'. The same metal also liberates gas 'G' when reacts with a base. 3

(i) Write the name of gas 'G'.

(ii) How will you test the presence of this gas?

(iii) Write chemical equations for the reactions of the metal with (1) an acid and (2) a base.

29. (a) Name the gland and the hormone secreted by it in scary situations in human beings. List any two responses shown by our body when this hormone is secreted into the blood. 3

OR

- (b) In the given diagram 3
- Name the parts labelled A, B, and C,
 - Write the functions of A and C.
 - Reflex arcs have evolved in animals? Why?

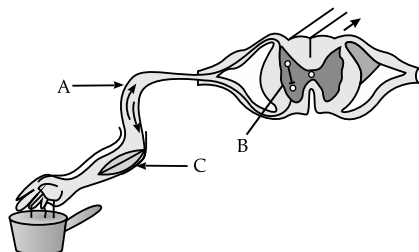

30. With the help of an appropriate example, justify that some of the chemical reactions are determined by 3
- Change in temperature,
 - Evolution of a gas, and
 - Change in colour
- Give chemical equation for the reaction involved in each case.
31. State reasons for Myopia. With the help of ray diagrams, show the 3
- image formation by a myopic eye, and
 - correction of myopia using an appropriate lens.
32. What is a solenoid? When does a solenoid behave as a magnet? Draw the pattern of the magnetic field produced inside it showing the directions of the magnetic field lines. 3
33. (a) Write the percentage of (i) solar energy captured by the autotrophs and (ii) energy transferred from autotrophs to the next level in a food chain. 3
- What are trophic levels? Why do different food chains in an ecosystem not have more than four to five trophic levels? Give reason.

SECTION — D

Q. No. 34 to 36 are Long Answer Questions.

34. (a) (i) A compound 'A' with a molecular formula of $C_2H_4O_2$ reacts with a base to give salt and water. Identify 'A', state its nature and the name of the functional group it possesses. Write chemical equation for the reaction involved. 5
- (ii) When the above stated compound 'A' reacts with another compound 'B' having molecular formula C_2H_6O in the presence of an acid, a sweet smelling compound 'C' is formed.
- Identify 'B' and 'C'.
 - State the role of acid in this reaction.
 - Write chemical equation for the reaction involved.

OR

- (b) (i) Name the compound formed when ethanol is heated at 443 K in the presence of conc. H_2SO_4 and draw its electron dot structure. State the role of conc. H_2SO_4 in this reaction. 5
- (ii) What is hydrogenation? Explain it with the help of a chemical equation. State the role of this reaction in industry.
35. Give reason for the following: 5
- During reproduction inheritance of different proteins will lead to altered body designs.
 - Fertilization cannot take place in flowers if pollination does not occur.

- (c) All multicellular organisms cannot give rise to new individuals through fragmentation or regeneration.
- (d) Vegetative propagation is practised for growing only some type of plants.
- (e) The parents and off-springs of organisms reproducing sexually have the same number of chromosomes.
36. (a) (i) What is meant by resistance of a conductor? Define its SI unit. 5
- (ii) List two factors on which the resistance of a rectangular conductor depends.
- (iii) How will the resistance of a wire be affected if its.
- (1) length is doubled, and
- (2) radius is also doubled ?
- Give justification for your answer.

OR

- (b) In an electric circuit three bulbs of 100 W each are connected in series to a source. In another circuit set of three bulbs of the same wattage are connected in parallel to the same source. 5
- (i) Will the bulb in the two circuits glow with the same brightness? Justify your answer.
- (ii) Now, let one bulb in both the circuits get fused. Will the rest of the bulbs continue to glow in each circuit ? Give reason for your answer.

SECTION — E

Q. No. 37 to 39 are case based / data based questions with 2 to 3 short sub-parts. Internal choice is provided in one of these sub-parts.

37. On the basis of reactivity metals are grouped into three categories: 4
- (i) Metals of low reactivity
- (ii) Metal of medium reactivity
- (iii) Metals of high reactivity
- Therefore metals are extracted in pure form from their ores on the basis of their chemical properties.
- Metals of high reactivity are extracted from their ores by electrolysis of the molten ore.
- Metals of low reactivity are extracted from their sulphide ores, which are converted into their oxides. The oxides of these metals are reduced to metals by simple heating.
- (a) Name the process of reduction used for a metal that gives vigorous reaction with air and water both
- (b) Carbon cannot be used as a reducing agent to obtain aluminium from its oxide? Why?
- (c) Describe briefly the method to obtain mercury from cinnabar. Write the chemical equation for the reactions involved in the process.

OR

- (c) Differentiate between roasting and calcination giving chemical equation for each.
38. All human chromosomes are not paired. Most Human Chromosomes have a maternal and a paternal copy and we have 22 such pairs. But one pair sex chromosomes is odd in not always being a perfect pair. Women have a perfect pair of sex chromosomes. But man have a mismatched pair in which one is normal sized while the other is a short one. 4
- (a) In humans, how many chromosomes are present in a zygote and in each gamete.
- (b) A few reptiles rely entirely on environmental cues for sex determinations. Comment.
- (c) The sex of a child is a matter of chance and none of the parents are considered to be responsible for it." Justify it through flow chart only.

OR

- (c) Why do all the gametes formed in human females have an X chromosome ?
39. Student took three concave mirrors of different focal lengths and formed the experiment to see the image formation by placing an object different distances with these mirrors as shown in the following table: 4

Case No.	Object-distance	Focal length
I.	45 cm	20 cm
II.	30 cm	15 cm
III.	20 cm	30 cm

Now answer the following questions:

- (a) List two properties of the image formed in Case I.
 (b) In which one of the cases given in the table the mirror will form real image of same size and why ?
 (c) Name the type of mirror used by dentists. Give reason why do they use such type of mirrors.

OR

- (c) Look at the table and identify the situation (object distance and focal length) which resembles the situation in which concave mirrors are used as shaving mirrors? Draw a ray diagram to show the image formation in this case.

Outside Delhi Set-2

31/6/2

Note: Except these, all other questions are from outside Delhi-Set-1

SECTION — A

(Multiple Choice Questions)

1. To balance the following chemical equation the values of x and y should respectively be : 1

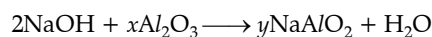

- (a) 1, 4 (b) 1, 2
 (c) 2, 4 (d) 2, 3
2. A solution turns the colour of turmeric to reddish brown. If the same solution is poured on universal indicator, its colour would change to : 1
- (a) violet (b) blue
 (c) red (d) green
5. Given below are two columns, Column I shows enzymes secreted by the glands in the alimentary canal of human beings and Column II indicates the components of food on which enzymes act. Choose the options showing correct matching: 1

	Column I (Enzymes)	Column II (Component)
(a)	Pepsin	Starch
(b)	Trypsin	Proteins
(c)	Lipase	Proteins
(d)	Amylase	Emulsified fat

7. To obtain a magnification of + 2 with a concave mirror of radius of curvature 60 cm, the object distance must be 1
- (a) – 90 cm (b) – 45 cm
 (c) – 30 cm (d) – 15 cm
13. The phenomena of light involved in the formation of rainbow are : 1
- (a) Refraction, dispersion and scattering.
 (b) Refraction, reflection and dispersion.
 (c) Refraction, dispersion and internal reflection.
 (d) Reflection, dispersion and total internal reflection.

Assertion–Reasoning based question:

These consists of two statements Assertion (A) and Reason (R). Answer these questions selecting the appropriate option given below :

- (a) Both Assertion (A) and Reason (R) are true and Reason (R) is the correct explanation (A)
- (b) Both Assertion (A) and Reason (R) are true but Reason (R) is not the correct explanation of (A).
- (c) Assertion (A) is true, but Reason (R) is false.
- (d) Assertion (A) is false, but Reason (R) is true.

18. **Assertion (A):** An ecosystem consists of biotic components and abiotic components.

Reason (R): Biotic and abiotic components play important roles for the sustenance of life and work independently in all ecosystems. 1

SECTION — B**(Very Short Answer Questions)**

21. A metal nitrate 'A' on heating gives a metal oxide along with evolution of a brown coloured gas 'B' and a colourless gas, which helps in burning. Aqueous solution of 'A' when reacted with potassium iodide forms a yellow precipitate.
- (a) Identify 'A' and 'B' 2
 - (b) Name the types of both the reactions involved in the above statement.
24. Three resistors of $6\ \Omega$, $4\ \Omega$ and $4\ \Omega$ are connected together so that the total resistance is $8\ \Omega$. Draw a diagram to show this arrangement and give reason to justify your answer. 2

SECTION — C**(Short Answer Questions)**

29. (a) Some plants like pea plants have tendrils which help them to climb up other plants. Explain how is it done. Name the plant hormone responsible for this movement. 3

OR

- (b) Name the phenomenon occurring in plants which are under the control of gravity, water and chemicals with one example each that shows the movement involved. 3
31. A reddish brown metal used in electrical wires when powdered and heated strongly turns black. When hydrogen gas is passed over this black substance, it regains its original colour. Based on this information answer the following questions: 3
- (a) Name the metal and the black substance formed.
 - (b) Write balanced chemical equations for the two reactions involved in the above information.
32. If a harmful chemical enters in a food chain comprising peacock, plants, rats and snakes, which of these organisms is likely to have the highest- concentration of the chemical in its body. Justify your answer. Name the process involved and define it. 3

SECTION — D**(Long Answer Questions)**

33. (a) (i) What are isomers? Write the structures of two compounds having molecular formula C_3H_6O and give their names. 5
- (ii) What are soaps? How are they chemically different from detergents? Why do soaps not work effectively in hard water?

OR

- (b) (i) What is a homologous series of carbon compounds ? Write general formula for alkynes. Name and draw the electron dot structure of first homologue of this series. 5
- (ii) State the meaning of the functional group in an organic compound. Write the formula of the functional group present in alcohols and carboxylic acids.

Note: Except these, all other questions are from outside Delhi-Set-1 and 2

SECTION — A

(Multiple Choice Questions)

4. There are four solution A, B, C and D with pH values of follows. 1

Solution	A	B	C	D
pH	2.0	7.0	8.0	12.0

Which solution(s) would liberate hydrogen gas with zinc ?

- (a) A only (b) D only
 (c) A and D (d) B and C

7. In torch lights and head lights of vehicles, the bulb is placed: 1

- (a) between the pole and the focus of the reflector.
 (b) very near to the focus of the reflector.
 (c) between the focus and centre of curvature of the reflector.
 (d) at the centre of curvature of the reflector.

10. Choose the option giving correct matching the items given in Column I & II. 1

Column-I	Column-II
A. Physical environment.	(i) Ozone layer depletion
B. Exposure to UV radiation	(ii) Bacteria and Fungi
C. Chlorofluoro Carbon compounds	(iii) Abiotic components
D. Decomposers	(iv) Skin Cancer

- | A | B | C | D |
|-----------|------|------|------|
| (a) (iii) | (i) | (iv) | (ii) |
| (b) (iii) | (iv) | (i) | (ii) |
| (c) (iii) | (iv) | (ii) | (i) |
| (d) (iii) | (i) | (ii) | (iv) |

11. The thread like structures that develop on a moist slice of bread in *Rhizopus* are : 1

- (a) Sporangia (b) Filaments
 (c) Rhizoids (d) Hyphae

12. The change in the focal length of an eye lens in human beings is caused by the action of 1

- (a) optic nerves (b) ciliary muscles
 (c) retina (d) cornea

Assertion–Reasoning based question:

These consists of two statements Assertion (A) and Reason (R). Answer these questions selecting the appropriate option given below :

- (a) Both Assertion (A) and Reason (R) are true and Reason (R) is the correct explanation (A)
 (b) Both Assertion (A) and Reason (R) are true but Reason (R) is not the correct explanation of (A).
 (c) Assertion (A) is true, but Reason (R) is false.
 (d) Assertion (A) is false. but Reason (R) is true.

19. **Assertion (A):** Testes in human males are located outside the abdominal cavity in scrotum.

Reason (R): Scrotum provides a lower temperature than the normal body temperature for sperm formation. 1

SECTION — B**(Very Short Answer Questions)**

22. (a) How is an electric impulse created in human nervous system? Identify the parts of a neuron which helps the nerve impulse to travel : 2
- (i) towards the cell body
- (ii) away from the cell body

OR

- (b) With the help of an example, explain how does the feedback mechanism regulate the hormone secretion. 2
26. Draw magnetic field lines produced around a straight current carrying conductor passing through a cardboard. How will the strength of the magnetic field change when the point where magnetic field is to be determined is moved away from the conductor ? 2

SECTION — C**(Short Answer Questions)**

28. (a) (i) What property do acids and bases have in common? Explain it with an example. 3
- (ii) A compound which is prepared from gypsum has the property of hardening when mixed with water. Identify the compound and write its formula. How is this compound prepared? Describe it in the form of a chemical equation only.

OR

- (b) (i) Write the chemical name and molecular formula of tooth enamel. 3
- (ii) How does it get corroded? What is the preventive measure for this?
31. A person is unable to see clearly a poster fixed on a distant wall. He however sees it clearly when standing at a distance of about 2 m from the wall. 3
- (a) Draw ray diagram to show the formation of image by his eye lens when he is far away from the wall.
- (b) List two possible reasons of this defect of vision.
- (c) Draw ray diagram to show the correction of this defect using appropriate lens.
33. State the change in colour observed in each of the following cases mentioning the reason : 3
- (a) Silver chloride is exposed to sunlight.
- (b) A piece of zinc is dipped in ferrous sulphate solution.
- (c) Copper powder is strongly heated in air.

SECTION — D**(Long Answer Questions)**

35. (a) Name the two types of pollination and differentiate between them. 5
- (b) Explain the post fertilization changes that occur in the ovary of a flower.
- (c) Given below is a diagram of a germinating seed. Label the parts that :
- (i) gives rise to future shoot.
- (ii) gives rise to future root system.
- (iii) stores food.

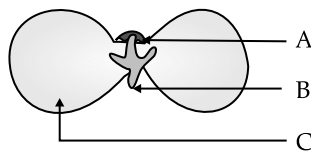

ANSWERS

SECTION — A

1. **Option (c) is correct.** 1

Explanation: When sodium hydrogen carbonate (sodium bicarbonate) is treated with dil. hydrochloric acid, a brisk effervescence is observed. This is due to release of carbon dioxide gas.

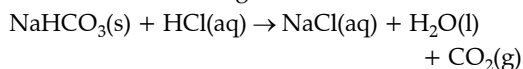

When carbon dioxide reacts with lime water, lime water turns milky due to the formation of calcium carbonate.

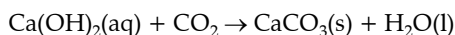

2. **Option (b) is correct.** 1

Explanation: When aqueous solution of potassium iodide and lead nitrate are mixed, an insoluble yellowish lead iodide is formed along with potassium nitrate.

The chemical reaction involved is:

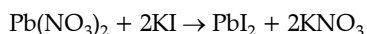

3. **Option (b) is correct.** 1

Explanation: X is Mg, Y is MgO and the type of reaction is combination reaction.

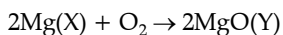

This is an example of combination reaction.

4. **Option (d) is correct.** 1

Explanation: The acid present in tomatoes is oxalic acid.

5. **Option (b) is correct.** 1

Explanation: An alkali is a base that dissolves in water hence, all alkalies are bases but all bases are not alkalies.

Sodium hydroxide is termed as alkali as it is a strong base as well as highly soluble in water. Ferric hydroxide is also a base, but it is not an alkali as it is not soluble in water.

6. **Option (c) is correct.** 1

Explanation: Sodium carbonate decahydrate (Washing soda: $\text{Na}_2\text{CO}_3 \cdot 10\text{H}_2\text{O}$) is used to remove the permanent hardness of water.

7. **Option (c) is correct.** 1

Explanation: The atomic number of chlorine is 17 so the electronic configuration of chlorine is 2,8,7. Since the outermost shell contains 7 valence electrons; hence, chlorine needs 1 more electron to complete its outermost shell. It combines with another chlorine atom by sharing 1 electron each to complete their

outermost shells.

The number of shared electrons is 2. Hence, the correct presentation of a chlorine molecule is:

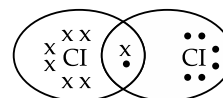

8. **Option (b) is correct.** 1

Explanation: The loss of water vapour through the stomata present on the surface of leaves is called transpiration. It creates a suction pressure for the upward movement of water in all tall trees.

9. **Option (b) is correct.** 1

Explanation: The opening and closing of the stomatal pore is the function of guard cells. They swell when water flows into them, causing the stomatal pore to open and on the loss of turgidity, the guard cells become flaccid leading to closure of the stomatal pore.

10. **Option (a) is correct.** 1

Explanation: A cross between pea plants with white flowers (vv) and pea plants with violet flowers (VV) resulted in F_1 progeny of violet flowers (Vv). On self pollinating the F_1 progeny, the ratio of violet (VV) and white (vv) flowers in F_2 is 1 : 1

F ₁ generation			
Parents	Vv	×	Vv
		↓	
Gametes	V		v
	V	VV (with violet flowers)	Vv (with white flowers)
F ₂ generation	v	VV (with violet flowers)	Vv (with white flowers)

11. **Option (a) is correct.** 1

Explanation: Cytokinin regulates the cell division by promoting it in the plants.

12. **Option (d) is correct.** 1

Explanation: The number of chromosomes in parents and offspring of a particular species undergoing sexual reproduction remain constant due to the halving of chromosomes through the process of meiosis at the time of gamete formation.

13. **Option (b) is correct.** 1

Explanation: In a series combination, current remains the same through all the devices. So, the current through the 6W bulb will also be 0.06 A.

14. Option (c) is correct.

1

Explanation: Applying the right hand thumb rule, the magnetic field formed will be opposite to each other but perpendicular to the plane of loop. At the center of loop, the field lines become straighter.

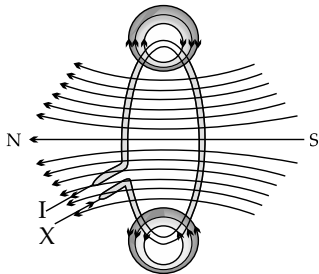
**15. Option (b) is correct.**

1

Explanation: The heat (H) produced is inversely proportional to resistance (R) so, if the resistance of a resistor (R) is reduced to half, the amount of heat (H) produced will get doubled.

For example; The heat produced in a circuit is given by:

$$H = \frac{V^2}{R \times t}$$

If $R' = \frac{R}{2}$

Then, $H' = \frac{2V^2}{R \times t} = 2H$

16. Option (d) is correct.

1

Explanation: Applying Fleming's left hand rule, the forefinger is directed towards the magnetic field while middle finger is towards the current, then the extended thumb shows the direction of force which is directed out of page, thus, the force experienced by the alpha particle will be out of the page.

17. Option (a) is correct.

1

Explanation: Exothermic reactions are those reactions in which heat is released along with the formation of products. Quicklime reacts vigorously with water releasing a large amount of heat along with the formation of calcium hydroxide. Therefore, it is an exothermic reaction.

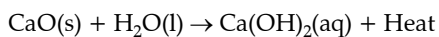
**18. Option (d) is correct.**

1

Explanation: In humans, if gene (B) is responsible for black eyes and gene (b) is responsible for brown eyes, then the colour of the eyes of the progeny having gene combination Bb and BB will be black only. The gene combination bb will be brown. It is because; black colour of the eyes is a dominant trait and brown eyes is a recessive trait.

19. Option (a) is correct.

1

Explanation: The inner lining of small intestine has finger like projections called villi which increase the surface area for absorption. The villi are richly supplied with the blood vessels which take the absorbed food to each and every cell of the body.

20. Option (b) is correct.

1

Explanation: A current carrying conductor experiences force when placed perpendicular to the direction of magnetic field. The current carrying conductor has only electrons flowing though it which experience force, not the protons which are stationary. Hence, the net charge on it is zero. Hence, the statements are correct but reason is not the correct explanation for assertion.

SECTION — B

21. (A) (i) The compound formed is Copper (II) chloride or cupric chloride (CuCl_2). $\frac{1}{2}$

The colour of CuCl_2 is blue-green. $\frac{1}{2}$

(ii) The balanced chemical equation is:

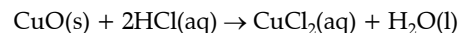

1

OR

(B) Compound X is NaCl(aq) , which is a concentrated aqueous solution of sodium chloride in water. $\frac{1}{2}$

Compound Y is H_2 (Hydrogen gas), liberated at cathode. $\frac{1}{2}$

Compound Z is Cl_2 , (Chlorine gas), liberated at anode. $\frac{1}{2}$

Treatment of gas Z (Cl_2) with dry slaked lime, Ca(OH)_2 , gives bleaching powder (CaOCl_2).

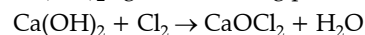

Hence, Compound B is CaOCl_2 $\frac{1}{2}$

The overall balanced chemical equation is:



22. (A) (i) Cerebellum $\frac{1}{2}$

(ii) Medulla $\frac{1}{2}$

(iii) Cerebrum $\frac{1}{2}$

(iv) Medulla $\frac{1}{2}$

OR

(B) Auxins are synthesized in the growing regions at the tip of the shoot and root in a plant. $\frac{1}{2}$

(i) Positive phototropism – Shoot $\frac{1}{2}$

(ii) Negative geotropism – Shoot $\frac{1}{2}$

(iii) Positive hydrotropism – Root $\frac{1}{2}$

23. (i) Renal artery carries nitrogenous excretory wastes towards the kidneys. $\frac{1}{2}$

(ii) Urethra releases urine out of the body. $\frac{1}{2}$

(iii) Glomerulus helps infiltration of blood passing through it and passes it on to the Bowman's capsule. $\frac{1}{2}$

- (iv) The tubular part of nephron reabsorbs useful products like glucose, amino acids, ions and a large amount of water into blood capillaries. $\frac{1}{2}$
24. Plants release oxygen during photosynthesis, which can be utilized by the plant for respiration. The plant kept in dark was not able to perform photosynthesis to generate some oxygen for respiration. **1**
The carbon dioxide released by the plant after respiration was utilized by the plants to photosynthesize food, hence, the plant was able to survive. **1**
25. (A) (i) Myopia, as image is formed before the retina for far away objects. $\frac{1}{2}$
(ii) **Possible causes are:**
(1) Elongation of eyeballs. $\frac{1}{2}$
(2) Excessive curvature of eye lens. $\frac{1}{2}$
(iii) **Correction:** Using concave lens of suitable focal length. $\frac{1}{2}$

OR

- (B) The sky appears blue because of the presence of atmosphere, which scatters maximum blue light. Since, Earth has atmosphere, so particles present in it, make scattering of light possible for blue colour. **1**
Space has no atmosphere so there is no intervening particle to obstruct light so as to scatter light. Hence, it appear dark from space. **1**
26. Pesticides are toxic, non-biodegradable substances that often run off into water bodies. Once, the toxin enters the body of living organisms, it is not metabolized or excreted, leading to its accumulation inside the body. The accumulation increases the concentration of toxin with each successive trophic level of the food chain, leading to a phenomenon called biological magnification.
The topmost trophic level accumulates the maximum amount of toxin, leading to severe health issues and sometimes the death of the individual. **2**

SECTION — C

27. (i) Water is a non-electrolyte so, the addition of acid will make it a good conductor of electricity. By this action, ions will be produced due to dissociation of acidified water that acts as a charge carriers for the faster conduction of electricity. $\frac{1}{2}$
The gas liberated at the cathode is Hydrogen gas. $\frac{1}{2}$
The gas liberated at the anode is Oxygen gas. $\frac{1}{2}$
In the electrolysis of water, the ratio of volumes of hydrogen and oxygen obtained is 2:1 i.e. 2 volumes of hydrogen and 1 volume of oxygen combines to form water. $\frac{1}{2}$
- (ii) When silver chloride is exposed to light, it decomposes to form silver metal and chlorine gas. $\frac{1}{2}$
The type of reaction is photolytic decomposition.

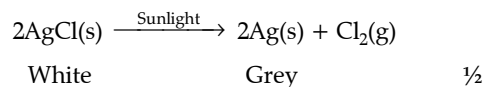

28. (i) The acid is always diluted by adding the acid to water slowly and with constant stirring. In addition to it, it is advised to wear gloves and goggles and maintain safe distance. **1**
- (ii) The salt formed when sulphuric acid is added to sodium hydroxide is sodium sulphate.
The balanced equation is:
$$2\text{NaOH} + \text{H}_2\text{SO}_4 \rightarrow \text{Na}_2\text{SO}_4 + 2\text{H}_2\text{O}$$

Its pH is approximately equal to 7. **1**
- (iii) The colour of litmus paper changes only in the presence of ions like hydrogen (H^+) or hydronium (H_3O^+) ions.
HCl can produce these ions only in the form of aqueous solution.
Hence, dry HCl gas does not change the colour of dry litmus paper. **1**
29. (A) (i) Paramecium takes its food at a specific spot by endocytosis. Food is moved to this spot by the movement of cilia which cover the entire surface of the cell. **1**
- (ii) (a) **Hydrochloric acid:** The hydrochloric acid creates an acidic medium which facilitates the action of enzyme pepsin and it also kills the germs in the food. $\frac{1}{2}$
- (b) **Trypsin:** Trypsin helps in digestion of proteins into smaller peptides. $\frac{1}{2}$
- (c) **Muscular wall of stomach:** The muscular wall of stomach help in mixing the food thoroughly with more digestive juices. $\frac{1}{2}$
- (d) **Salivary amylase:** Saliva contains an enzyme called salivary enzyme which breaks down starch to give simple sugar. $\frac{1}{2}$

OR

- (B) (i) Double circulation is the process during which blood passes twice through the heart during one complete cycle. Blood is circulated to the body tissues through systemic circulation and to the lungs through pulmonary circulation. **1**
- (ii) The separation of right side and left side of the heart helps in separation of oxygenated and deoxygenated blood, which allows a more efficient supply of oxygen to the body cells. **1**
Birds and mammals are warm blooded animals. Since, they require more energy to maintain a constant body temperature; hence, the separation provides availability of oxygen during respiration to generate more energy for thermoregulation. **1**
30. (i) **Principal focus:** It is the point on the axis of a mirror to which parallel rays of light appear to diverge after reflection from diverging mirror. **1**
- (ii) **Focal length:** The distance between pole of convex mirror and principal focus. **1**

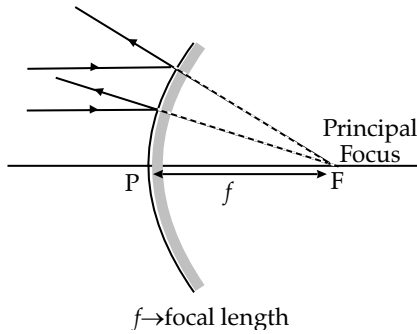

OR

(B) Given, Object's height

$$h_0 = 10 \text{ cm}$$

$$\text{Object distance } u = -25 \text{ cm}$$

Focal length of convex lens

$$f = 15 \text{ cm}$$

$$\text{Image distance } v = ?$$

$$\text{Height of image } h_i = ?$$

Using the lens formula:

$$\frac{1}{f} = \frac{1}{v} - \frac{1}{u}$$

$$\text{or, } \frac{1}{v} = \frac{1}{f} + \frac{1}{u}$$

$$\text{or, } \frac{1}{v} = \frac{1}{15} + \frac{1}{-25}$$

$$\frac{1}{v} = \frac{5-3}{75}$$

$$\text{So, image distance } (v) = \frac{75}{2} = 37.5 \text{ cm}$$

From the magnification:

$$\frac{h_i}{h_0} = \frac{v}{u}$$

$$h_i = \frac{v}{u} \times h_0$$

$$= \frac{37.5 \times 10}{-25.0}$$

$$h_i = -15 \text{ cm}$$

An inverted image of 15 cm which will be formed at 37.5 cm from the given lens. 3

31. Given: Power of lens P = + 4D

$$\text{Since, } f = \frac{1}{P} = \frac{1}{4} \text{ m}$$

$$f = 0.25 \text{ m} = 25 \text{ cm}$$

Since, power is positive, so the lens is convex.

$$\text{Now, } u = -50 \text{ cm}$$

Using lens formula:

$$\frac{1}{f} = \frac{1}{v} - \frac{1}{u}$$

$$\frac{1}{v} = \frac{1}{f} + \frac{1}{u}$$

$$\frac{1}{v} = \frac{1}{25} + \frac{1}{-50}$$

$$\frac{1}{v} = \frac{2-1}{50}$$

$$v = 50 \text{ cm}$$

$$\text{magnification } (m) = \frac{v}{u} = \frac{50}{-50} = -1$$

Since, image distance is positive and its magnification is -1 , it indicates a real, inverted and image of same size. 3

32. (A) (i) Alternating current can be transmitted over long distances at very high voltages so as to ensure that current value is very low and as a result very low amount of energy is lost during transmission. When it reaches near the household, the voltage can be stepped down to restore required value of current whereas the voltage of direct current cannot be stepped up and down. 1

(ii) The type of current used in domestic household supply is alternating while a battery of dry cells supplies direct current. 1

(iii) Electric fuse is made of wires of very low melting point. If there is a current larger than the specified value, the temperature of fuse wire increases and it melts to break the electric circuit and stop the flow of unduly high electric current. This saves appliances from possible damage. 1

OR

(B) (i) The field strength will be maximum at point A as A is inside the solenoid where the field lines have highest density. 1

(ii) The field strength will be minimum at point B as field lines have least density. 1

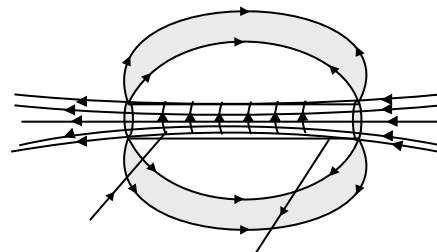

33.

	Biodegradable Substances	Non-biodegradable substances
(i)	Substances that can be decomposed naturally by the action of micro-organisms.	Substances that cannot be decomposed naturally.

(ii)	It is environment-friendly.	It is harmful to the environment and causes pollution.
------	-----------------------------	--

(Any one) $\frac{1}{2} + \frac{1}{2}$ **Effects of biodegradable substances on environment:**

- (i) Decomposition of biodegradable wastes is accompanied by foul smell which spreads in the environment and affects the people of nearby areas.
- (ii) It act as breeding grounds for houseflies, etc. which act as vectors of various diseases. $\frac{1}{2} + \frac{1}{2}$

Effects of non-biodegradable substances on environment:

- (i) Excessive use of non-biodegradable pesticides increases the soil pollution and also affects the soil fertility.
- (ii) Certain non-biodegradable wastes enter the food chains and affects the various biotic components of the environment. $\frac{1}{2} + \frac{1}{2}$

SECTION — D

34. (A) (i) (a) The structure of butanoic acid is:

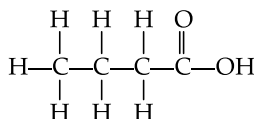

1

- (b) The structure of chloropentane is:

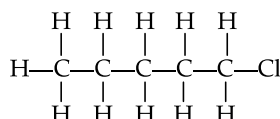

- (ii) Structures (i) and (ii) are structural isomers of each other as they have different structures but same molecular formula (
- C_6H_{14}
-). 1

Another structural isomers is n-Hexane.

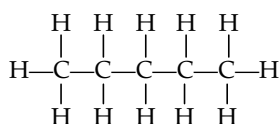

- (iii) Difference between saturated and unsaturated compounds are:

Saturated compounds	Unsaturated compounds
They have single bonds between carbon atoms.	They have at least one double or triple bond between carbon atoms.
Their general formula is $\text{C}_n\text{H}_{2n+2}$.	Alkenes (which have double bond) have general formula as C_nH_{2n} . Alkynes (which have triple bond) have general formula as $\text{C}_n\text{H}_{2n-2}$.

 $\frac{1}{2} + \frac{1}{2}$

OR

- (B) (i) Ethanol reacts with sodium to produce hydrogen gas and sodium ethoxide.

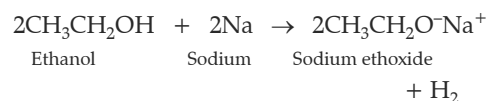

Ethanol Sodium Sodium ethoxide

Hydrogen gas 1

- (ii) The freezing point of pure ethanoic acid is 290 K and hence, it freezes during winter in cold climates. That is why; it is called as glacial acetic acid. 1

- (iii) When ethanol is heated with concentrated sulphuric acid at 443 K, it loses one water molecule and forms ethene.

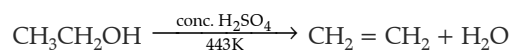

Ethanol Ethene Water 1

- Role of H_2SO_4 :**
- It acts as dehydrating agent and removes water molecules from ethanol. 1

- (iv) Equation for saponification reaction:

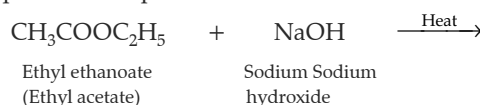

Ethyl ethanoate Sodium Sodium hydroxide

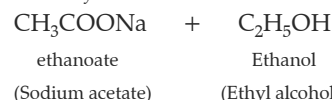
ethanoate Ethanol
(Sodium acetate) (Ethyl alcohol)

35. (i) The two modes of asexual reproduction observed in
- Hydra*
- are : Budding and Regeneration.
- $\frac{1}{2} + \frac{1}{2}$

Budding in *Hydra*: In Budding, a small part of the body of the parents grows out as a 'bud' which then detaches and becomes a new organism. *Hydra* reproduces by budding using the regenerative cells. A bud develops as an outgrowth in *Hydra* due to repeated cell division at one specific site. When fully mature, the bud detaches itself from the parent body and develops into new independent individuals.

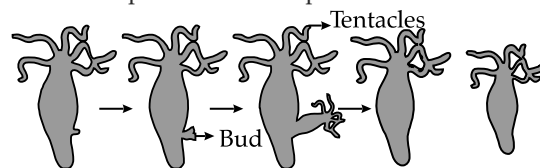

1

Regeneration in *Hydra*: In this method, small cut or broken parts of the organisms' body grow or regenerate into separate individuals. Regeneration of *Hydra* from the body parts is carried out by specialized cells, which proliferate and make a large number of cells.

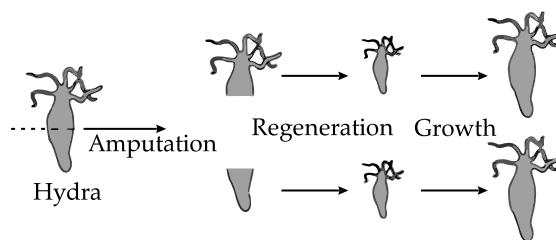

1

- (ii) Vegetative propagation is the development of a new plant from the vegetative parts (roots, stem and leaves) of a plant. **1**

Advantages:

- (i) Such plants can bear flowers and fruits earlier than those produced from seeds.
 (ii) Allows propagation of plants (banana, orange etc) that have lost capacity to produce seeds.
 (iii) All plants produced are genetically similar to the parent plant and hence have all its characters.

(Any two) 1+1

36. (i) The ratio of potential difference to the flow of current in conductor is constant which is called the resistance of the conductor provided the physical conditions of the conductor remains constant. This is called Ohm's Law.

Mathematically, $\frac{V}{I} = R$ (constant) **1**

Circuit diagram:

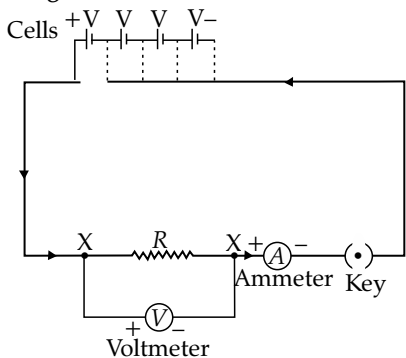

XY → Nichrome wire (Resistance)

- (ii) An ammeter is a device used to measure the amount of current flowing in a circuit. The resistance of an ideal ammeter should be zero as it is always connected in series in a circuit. Hence, its resistance adds to the total resistance of the circuit. If the resistance of the ammeter would be high, then the total resistance would be too high. This in turn would decrease the amount of current flowing through the circuit. **1**
- (iii) The slope of I-V graph gives the reciprocal of resistance. So, the graph with a lesser slope will indicate a larger resistance.
 The series combination of resistances has a large net resistance than the corresponding parallel combination. So, Graph A indicates series combination and graph B indicates parallel combination. $\frac{1}{2} + \frac{1}{2}$

SECTION — E

37. (A) (i) Electron transfer in the formation of magnesium chloride:

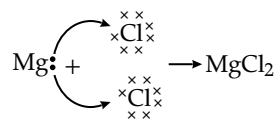
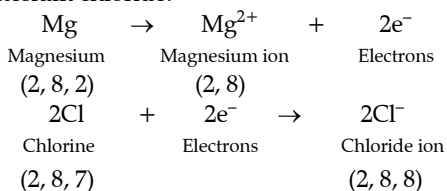

- (ii) **Two properties of ionic compounds are:**

- (a) They conduct electricity in solution or molten state.
 (b) They are hard and brittle crystalline solids.

$\frac{1}{2} + \frac{1}{2}$

- (iii) (A) Sodium chloride is formed by the combination of sodium and chloride ions. Sodium loses one electron from valence shell to attain stable noble gas configuration.

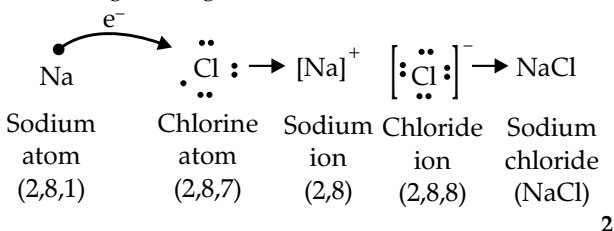

OR

- (B) (i) Ionic compounds do not conduct electricity in solid state due to the absence of free ions but they conduct electricity in molten and aqueous state due to presence of free ions. **1**
- (ii) Reduction takes place at cathode. Therefore, during electrolysis of aqueous solution of sodium chloride, hydrogen gas is evolved at cathode due to reduction of H⁺ ions.

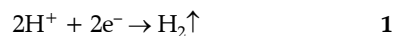

38. (i) An offspring is not a true copy of his parents in sexual reproduction because of variations due to recombination of genetic material from two different parents. **1**
- (ii) All the F₁ offspring are genetically identical and exhibit the dominant trait. $\frac{1}{2}$
 F₂ offspring can exhibit a range of dominant to recessive traits. $\frac{1}{2}$
- (iii) (A) Variations help the organism to become more adapted to the changing environmental conditions. This helps the organisms to overcome the adverse conditions. **2**

OR

- (B) Round Green and Wrinkled Yellow are the new combinations in F₂ generation. **1**
 New features which are not present in parents appear in F₂ generation due to the segregation of different combinations of alleles of different characters independently during gamete formation and fertilisation. **1**

39. (i) Since,

$$\text{Refractive index } (\mu) = \frac{\text{Speed of light in vacuum } (c)}{\text{Speed of light in any medium } (v)}$$

$$\text{Therefore; } v = \frac{c}{\mu}$$

$$\text{Given: } \mu = 2.42, c = 3 \times 10^8 \text{ m/s}$$

So, speed of light in diamond

$$v_D = \frac{3.0 \times 10^8}{2.42} \\ = 1.24 \times 10^8 \text{ m/s} \quad 1$$

(ii) Carbon disulphide is most dense and water is least dense.

From Snell's law:

$$\mu = \frac{\sin i}{\sin r} \\ \sin r = \frac{\sin i}{\mu}$$

Since, $\sin i$ is same.

$$\text{So, } \frac{\sin i}{1.33} > \frac{\sin i}{1.5} > \frac{\sin i}{1.62}$$

Hence, for angle of refraction increasing order will be: $r_{cs} < r_g < r_w$ 1

(iii) (A) (a) Speed of light is more in rarer medium than denser medium. So, glass is denser. 1

(b) When light is incident normally at water-glass interface, it goes straight through the medium with no bending. It is because, by bending light prefers to go shortest path. In case when normally incident, it is already along shortest path. 1

OR

$$\text{(iii) (B) Since, } \mu = \frac{c}{v}$$

$$\text{Given, } \mu_w = \frac{4}{3} \text{ and } \mu_g = \frac{3}{2}$$

Speed of light in glass

$$v_g = 2 \times 10^8 \text{ m/s}$$

$$\text{(i) } \mu_g = \frac{c}{v_g}$$

$$\text{or, } c = \mu_g \times v_g$$

$$c = \frac{3}{2} \times 2 \times 10^8 \text{ m/s}$$

$$c = 3 \times 10^8 \text{ m/s} \quad 1$$

$$\text{(ii) Since, } \mu_w = \frac{c}{v_w}$$

$$\text{or, } v_w = \frac{3 \times 10^8}{\frac{4}{3}}$$

$$v_w = 2.25 \times 10^8 \text{ m/s} \quad 1$$

Delhi Set-2

31/4/2

SECTION — A

9. Option (c) is correct. 1

Explanation: Sexual maturation of reproductive tissues is a necessary link for reproduction because of the need for germ-cells to participate in sexual reproduction. The body of the individual organism has to grow to its adult size, the rate of general body growth begins to slow down and reproductive tissues begin to mature during adolescence.

10. Option (c) is correct. 1

Explanation: In humans, all eggs of female carry X chromosome while sperms may have X or Y chromosome. The sex of the child depends on the type of sperm that fuses with the egg. If the egg fuses with the sperm carrying X chromosome, it results in a girl (XX) and if it fuses with the sperm carrying Y chromosome, it results in a boy (XY).

11. Option (b) is correct. 1

Explanation: During photosynthesis, plants take in carbon dioxide (CO₂) and water (H₂O) from the air

and soil. Within the plant cell, the water is oxidized, meaning it loses electrons, while the carbon dioxide is reduced, meaning it gains electrons. This transforms the water into oxygen and the carbon dioxide into glucose.

16. Option (c) is correct. 1

Explanation: When two LED bulbs are connected in series, the current flowing through both the bulbs is the same. Therefore, the current flowing through the 10W bulb will also be 0.005A.

SECTION — B

21. (i) The function of the ozone layer in the upper atmosphere is to prevent harmful ultraviolet (UV) rays from reaching the Earth's surface, as these UV rays cause various types of diseases including skin cancer. 1

(ii) The amount of ozone in the atmosphere began to drop sharply in the 1980s. This decrease is due to synthetic chemicals like chlorofluorocarbons which are used as refrigerants and in fire extinguishers. 1

24. (i) Bile juice has bile salts such as bilirubin and biliverdin. These break down large fat globules into smaller globules so that the pancreatic enzymes can easily act on them. This process is known as emulsification of fats. 1
- (ii) Bile juice also makes the medium alkaline and activates lipase. 1
25. Adrenaline or epinephrine ½
- The three responses that enable the animal body to deal with it are:**
- (i) **Increased heart rate:** Adrenaline increases heart rate, enabling the animal to pump more blood and oxygen to the muscles. This helps the animal to react quickly to the perceived danger. ½
- (ii) **Dilated pupils:** Adrenaline causes the pupils to dilate, which helps the animal to see more clearly in low light conditions. This is essential for detecting potential threats and reacting quickly. ½
- (iii) **Increased blood sugar:** Adrenaline increases the release of glucose from the liver into the bloodstream, providing the animal with a quick source of energy. This helps the animal to perform physical activities required to defend it or escape from danger. ½

SECTION — C

29. **Two differences in the characteristic properties of the virtual images formed by concave and convex lenses are:**
- (i) Concave lenses always form virtual, erect and smaller images, while convex lenses can form virtual, erect, and magnified or real, inverted, and magnified images depending on the position of the object. 1
- (ii) The position of the virtual image formed by a concave lens is always behind the lens, while the position of the virtual image formed by a convex lens can be in front of, behind or at the same position as the lens. 1
- The characteristic properties of concave and convex lenses are used in the correction of myopia and hypermetropia as:**
- (1) **Myopia:** A concave lens is used to correct myopia. Concave lens diverge the light rays before they enter the eye, thereby making the virtual image formed on the retina. ½
- (2) **Hypermetropia:** A convex lens is used to correct hypermetropia. Convex lens converge the light rays before they enter the eye, thereby making the virtual image formed on the retina. ½
30. (A) (i) Convex lens or a converging lens because its power is positive (+2D).
- (ii) The formula for power (P) is:

$$P = \frac{1}{\text{focal length}(f)}; P = +2D$$

$$\text{Therefore, } f = \frac{1}{P} = \frac{1}{2} = 0.5 \text{ m.}$$

Now, we can use the lens formula to calculate the image distance as:

$$\frac{1}{f} = \frac{1}{v} - \frac{1}{u}$$

Where f is the focal length, u is the object distance, and v is the image distance.

As; $u = -1 \text{ m}$, $f = 0.5 \text{ m}$ hence;

$$\frac{1}{0.5} = \frac{1}{v} - \frac{1}{-1}$$

$$v = 1.0 \text{ m}$$

Therefore, the focal length of the lens is 0.5 m and the image is formed at a distance of 1.0 m from the lens.

32. (i) Water is non-electrolyte so, the addition any acid will make it a good conductor of electricity. When we add an acid in water, ions will be produced due to dissociation of acidified water that acts as a charge carriers for the faster conduction of electricity. 1
- (ii) $\text{KOH} + \text{H}_2\text{O} \longrightarrow \text{K}^+ + \text{OH}^-$
(Potassium hydroxide) (Water) 1
- (iii) Concentrated nitric acid reacts vigorously with water releasing a large amount of heat which may cause splashing out of the solution or breaking of container and cause burns. Therefore, the acid must always be added slowly to water with constant stirring. 1

SECTION — D

36. (A) (i) Covalent compounds are bad conductors of electricity because they do not have free electrons or ions that can move and carry an electric current. 1
- (ii) The atomic number of Carbon is 6 with an electronic configuration of 2, 4. Hence, carbon has 4 electrons in its valence shell. Carbon can lose or gain 4 electrons in order to gain stability. It cannot gain four electrons as carbon atom having 6 protons is very small to handle 10 electrons and it cannot donate electrons as it needs a lot of energy to do so. Hence, it cannot form C^{4+} cation or C^{4-} anion and thus forms a covalent bond. 1
- (iii) The electron dot structure of Ethanol is:
- $$\begin{array}{c} \text{H} \quad \text{H} \\ \vdots \quad \vdots \\ \text{H} : \text{C} : \text{C} : \text{O} : \text{H} \\ \vdots \quad \vdots \quad \vdots \\ \text{H} \quad \text{H} \end{array}$$
- 1
- (iv) Heteroatoms are the elements that replace hydrogen in a hydrocarbon.
- (a) Oxygen ½
- (b) Chlorine ½

OR

- (i) Soaps are the sodium or potassium salts of long-chain fatty acids. They are formed by the reaction between an alkali (sodium hydroxide or potassium hydroxide) and a fat or oil. ½

Cleansing action of soap:

- The long hydrocarbon chain of the soap is non-polar and tends to avoid water. When soap is added to water, the hydrophobic tail is attracted to the dirt, oil or grease, while the hydrophilic head is attracted to the water molecules.
- The hydrophobic tail surrounds the oil or grease droplet, forming a sphere called a micelle.

- The soap molecules on the outside of the micelle are attracted to the water molecules and are washed away with the water, carrying the micelle and dirt along with it.
- When the soap and water are rinsed off, the dirt, oil, and grease are removed from the surface.

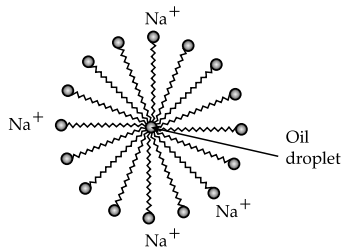
 $\frac{1}{2} \times 4$  $\frac{1}{2}$

Formation of micelles

(ii) Detergents are better than soaps as:

- Detergents work better in hard water than soaps as they do not react with the minerals in hard water to form insoluble compounds.
- Detergents can be used in both hot and cold water, whereas soaps work better in hot water.
- Detergents are more effective in removing grease and oil stains than soaps.
- Detergents are less likely to leave a residue on clothes, unlike soaps.

(Any two) 1+1

Delhi Set-3

31/4/3

SECTION — A

9. **Option (b) is correct.** 1

Explanation: Water in the root enters due to difference in the concentration of ions between the root and the soil.

10. **Option (d) is correct.** 1

Explanation: Changes in protein structure can cause changes in the characteristic of an organism, as proteins are the molecules responsible for carrying out various functions in the cell.

11. **Option (a) is correct.** 1

Explanation: Sensory nerve of a reflex arc carries information from the receptor cells to the spinal cord. It is also called as afferent neuron.

SECTION — B

21. Auxin is a plant growth hormone that is synthesized at the shoot tip, which is responsible for bending of a shoot of a plant when it is exposed to unidirectional light. 1

When the growing parts of a phototropic plant detect sunlight, auxins (synthesized at the shoot tips) help the cells grow longer. When light falls on one side of the plant, the auxins generally diffuse towards the shaded side of the shoot. This stimulates the cells in the shaded area to grow longer than the corresponding cells of the illuminated region. This results in the curvature of the plant stem tip towards the light. 1

24. Another name for tissue fluid is interstitial fluid. 1

Functions:

- (i) Tissue fluid acts as a middle man. It hands over food materials and oxygen from the blood to the tissue cells and receives CO_2 , nitrogenous wastes, hormones and other synthetic substances from the tissue cells and discharges them into blood. $\frac{1}{2}$

- (ii) It also keeps the tissue cells moist. $\frac{1}{2}$

25. All the interacting organisms in an area together with the abiotic constituents of the environment form an ecosystem. Various kinds of plants such as grasses, trees, shrubs and many flower bearing plants and animals like frogs, squirrels, calotes, insects, birds, etc. are found in garden. All these organisms interact with each other. Their growth, reproduction and other activities are affected by the abiotic components such as light, wind, water, minerals, soil, etc. So, a garden is considered as an ecosystem. 2

SECTION — C

27. (a) Sodium chloride (NaCl) is a normal salt that is formed by the complete neutralization of hydrochloric acid by sodium hydroxide. The neutralization reaction can be represented as:

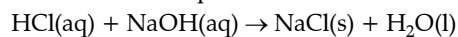

Since the sodium chloride is formed by the complete neutralization reaction. Hence, sodium chloride is neutral. Hence, the pH of sodium chloride is 7. 1

- (b) Ammonium nitrate (NH_4NO_3) is acidic in nature since it is derived from a weak base (NH_3) and a strong acid (HNO_3). Universal Indicator turns red in acids. 1

- (c) Potassium carbonate (K_2CO_3) is formed from a weak acid, carbonic acid (H_2CO_3), and a strong base, potassium hydroxide (KOH). On hydrolysis, K_2CO_3 forms more OH^- ions than H^+ ions. Thus, it is basic and therefore turns red litmus blue. 1

33. The splitting of beam of white light into its seven constituent colors, when it passes through a glass prism, is called the dispersion of light. 1

- (i) The violet colour bends the most while (ii) the red colour bends the least while passing through a prism. 1

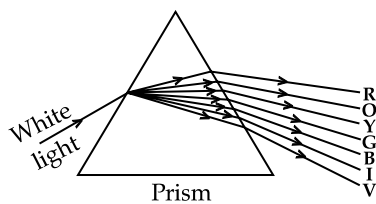

1

OR

A rainbow is a band of colors. It is a natural spectrum appearing in the sky after rain. It is formed by the dispersion of sunlight by tiny water droplets in the sky.

1

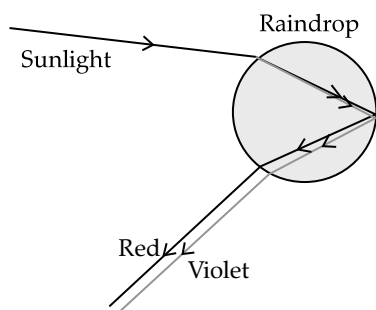

2

SECTION — D

36. (A) (i) Combustion of methane:

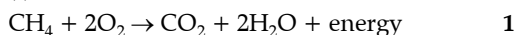

(ii) Oxidation of ethanol:

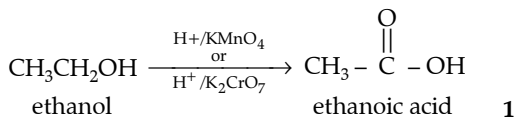

(iii) Hydrogenation of ethene:

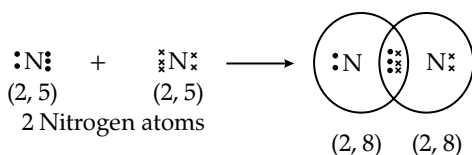
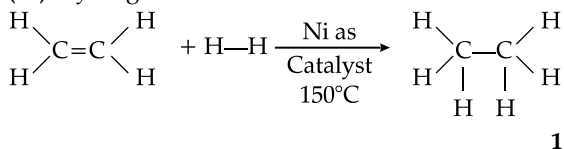

(iv) Esterification reaction:

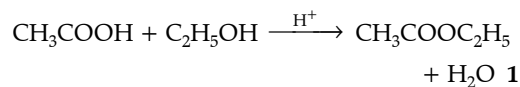

(v) Saponification reaction:

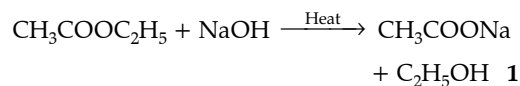

OR

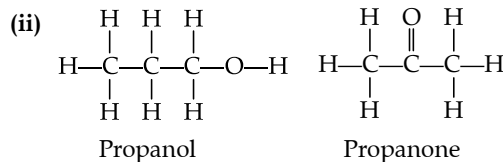
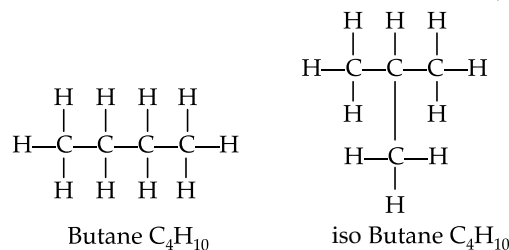
(B) (i) Structural formulae of isomers of Butane are: *n*-butane and isobutane. $\frac{1}{2} + \frac{1}{2}$ (iii) (a) 3rd homologue of alcohol is propanol ($\text{C}_3\text{H}_7\text{OH}$). $\frac{1}{2}$ (b) 3rd homologue of aldehyde is propanal ($\text{CH}_3\text{CH}_2\text{CHO}$) $\frac{1}{2}$ (iv) (a) Benzene (C_6H_6) $\frac{1}{2}$ (b) 1- Butene $\frac{1}{2}$

(v) Covalent bond formation in Nitrogen molecule:

Triple bond

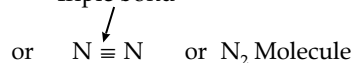
**Outside Delhi Set-1**

31/6/1

SECTION — A

1. Option (b) is correct. 1

Explanation: Some metal oxides, such as aluminum oxide, zinc oxide, etc., show both acidic as well as basic behavior. Such metal oxides can react with both acids as well as bases to produce salts and water. Metal oxides of this category are known as amphoteric oxides.

2. Option (c) is correct. 1

Explanation: Ammonium chloride is a salt of strong acid like (hydrochloric acid) and a weak base (like

ammonium hydroxide). It is acidic in nature and pH less than 7.

Universal indicator paper gives pink solution in acidic medium.

3. Option (b) is correct. 1

Explanation: Zinc sulphate (ZnSO_4) is acidic solution and hydrogen (H_2) is a gas.

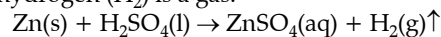

4. Option (a) is correct. 1

Explanation: Phenolphthalein gives pink colour in a basic pH range from 8.2 to 10. When phenolphthalein is added to Na_2CO_3 solution, which is a basic solution, the solution will turn pink in colour. However, when

phenolphthalein is added to NH_4Cl , which is acidic solution, the solution will remain colourless.

5. **Option (b) is correct.** 1

Explanation: The label 1 is nucleus, label 2 is chloroplast, label 3 is vacuole and label 4 is guard cell.

6. **Option (c) is correct.** 1

Explanation: Walking in a straight line and riding a bicycle are voluntary actions and are controlled by cerebellum. Cerebellum controls voluntary actions such as body posture and balance of the body. Involuntary actions such as vomiting, blood pressure are under the control of medulla of hind brain.

7. **Option (a) is correct.** 1

Explanation: Object distance should be less than the focal length for the formation of an erect image. Hence, the range of distance of object from the mirror should be less than 10 cm i.e., from 0 to 10 cm in the front of mirror from the pole. The nature of image so formed will be virtual and erect.

8. **Option (d) is correct.** 1

Explanation: Bronze is an alloy of copper and tin.

9. **Option (c) is correct.** 1

Explanation: When a pure tall plant (TT) is crossed with the pure short plant (tt), then the progeny in the F_1 generation will be hybrid (Tt). When the F_1 generation is self-crossed (Tt), then in the F_2 generation, the progeny produced will be tall homozygous (TT), Tall heterozygous (Tt), and dwarf homozygous (tt). Hence, the ratio of pure tall plant to pure short plants in F_2 generation will be 1 : 1 (TT : tt)

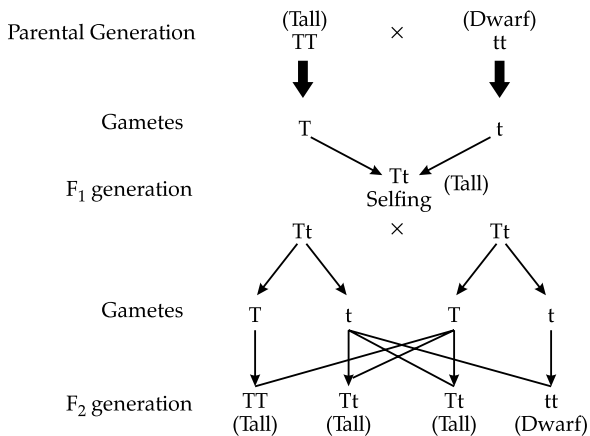

10. **Option (d) is correct.** 1

Explanation: Primary consumers make up the second trophic level. They are also called herbivores. They eat primary producers. In the given food web, Mice and Rabbit are primary consumers.

11. **Option (b) is correct.** 1

Explanation: *Leishmania* has a whip like structure at one end of the cell. Hence, binary fission occurs in a definite orientation in relation to this structure hence, the correct order of stages of binary fission in *Leishmania* is : I, III, II, V, IV.

12. **Option (b) is correct.** 1

Explanation: The chemical equation I represents a displacement reaction. In this, Mg metal displaces hydrogen from HCl. In a displacement reaction, a more reactive element displaces a less reactive element from its salt solution.

The chemical equation II is an example of double displacement reaction because both the ions from each of the reactant (NaOH and HCl) are displaced with another reactant.

13. **Option (b) is correct.** 1

Explanation: The phenomenon of splitting of white light into its seven constituent colours when it passes through a glass prism is called dispersion of white light. The various colours seen are Violet, Indigo, Blue, Green, Yellow, Orange and Red. The different component colour of light bends at a different angle w.r.t the incident angle.

The order of deviation of colour from most to least is: Violet > Indigo > Blue > Green > Yellow > Orange > Red

Thus, here the colour P is Violet and colour Q is Red.

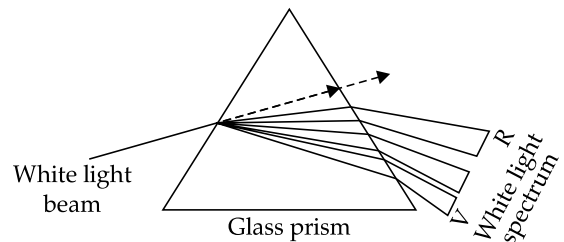

14. **Option (c) is correct.** 1

Explanation: Fertilization occurs inside the ovary female reproductive part (carpel). After fertilization the ovary develops into a fruit. In this case, flower Z lacks carpel so it could not develop into fruit. The flowers X and Y would develop into a fruit.

15. **Option (d) is correct.** 1

Explanation: The magnetic field inside a long straight solenoid-carrying current is generally the same at all points inside a magnetic field.

16. **Option (b) is correct.** 1

Explanation: The pupil is the opening at the center of the iris through which light passes.

17. **Option (d) is correct.** 1

Explanation: We should add acid to water and not water to acid. It is highly exothermic and may cause burns. Hence, assertion is false but reason is true.

18. Option (c) is correct. 1

Explanation: The flow of energy is unidirectional. The energy that is captured by the autotrophs does not revert to the Sun and the energy which passes to the herbivores does not come back to autotrophs. As it moves progressively through the various trophic levels, it is no longer available to the previous level.

19. Option (c) is correct. 1

Explanation: Amoeba takes in food using temporary finger-like extensions of the cell surface, called pseudopodia, which extend and fuse over the food particle forming a food-vacuole. Inside the food vacuole, complex substances are broken down into simpler ones which then diffuse into the cytoplasm. A unicellular organism does not need specific organ for taking in food, because the entire surface of the organism is in contact with the environment.

20. Option (a) is correct. 1

Explanation: The melting point and boiling point of ethanol are indeed lower than that of sodium chloride. This is because ethanol is a covalent compound, while sodium chloride is an ionic compound. Covalent compounds have weaker intermolecular forces than ionic compounds, which mean less energy is required to break the bonds holding the molecules together. Therefore, covalent compounds tend to have lower melting and boiling points than ionic compounds.

SECTION — B

21. The given reaction is an example of a redox reaction because the oxidation and reduction are taking place simultaneously in the reaction.

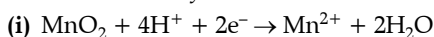

As you can see in this reaction, MnO_2 is converted to Mn^{2+} because addition of electrons takes place in this reaction, hence we can say that MnO_2 is the compound which is reduced. 1

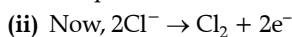

In this reaction, Cl^- is oxidized to Cl_2 because removal of electrons takes place. Hence, we can say that the compound which is oxidized is HCl. 1

22. The type of movement of leaves of the sensitive plant is known as a nastic movement. This type of movement does not depend on the direction of stimuli. 1

The movement of shoot towards light is known as a tropic movement. This movement depends on the direction of light. Hence, Refractive index of medium B with respect to medium A = n_B/n_A This type of movement is directional and growth development. 1

OR

Transmission of nerve impulses between two neurons takes place through the synapse. At the end of the axon, the electrical impulse sets off the release of some chemicals called neurotransmitters. These chemicals cross the gap or synapse and start a similar electrical impulse in the dendrite of the next neuron. 2

23. Ptyalin or salivary amylase is the starch hydrolyzing enzyme secreted by salivary glands in human beings. $\frac{1}{2} + \frac{1}{2}$

Amylase is a digestive enzyme that acts on starch in food, breaking it down into smaller carbohydrate molecules. Without amylase, a person will be unable to digest starch and sugars in the mouth. 1

24. From Ohm's Law:

$$V = IR$$

Since the resistance is constant and the potential difference is decreased to one-fourth of the initial value. Thus, the current through the component will also decrease to one fourth of its initial value. 1

Ohm's law states that the current through a conductor between two points is directly proportional to the potential difference across the two points provided physical conditions are remain same. 1

25. (a) As it is clear from the figure, when the light ray travelled from medium A to medium B, then it bends towards the normal which means that medium B is optically denser than medium A. 1

(b) Refractive index of medium A μ_A

$$= \frac{\text{Speed of light in vacuum}(c)}{\text{Speed of light in medium A}(v_A)}$$

Or $\mu_A = \frac{c}{v_A}$

Refractive index of medium B μ_B

$$= \frac{\text{Speed of light in vacuum}(c)}{\text{Speed of light in medium B}(v_B)}$$

Or $\mu_B = \frac{c}{v_B}$

Now, refractive index of medium B with respect to A

$$\frac{\mu_B}{\mu_A} = \frac{\frac{c}{v_B}}{\frac{c}{v_A}}$$

$$\frac{\mu_B}{\mu_A} = \frac{v_A}{v_B}$$

2

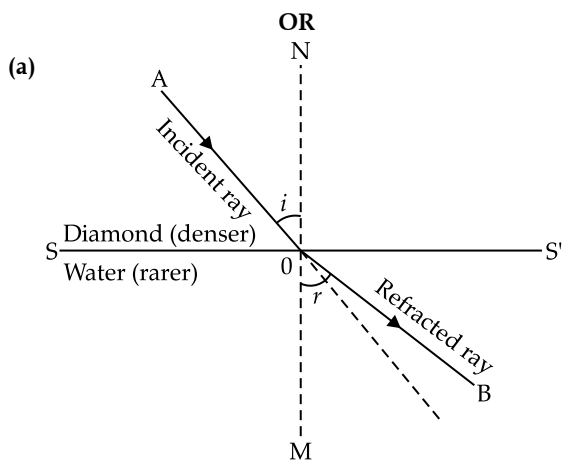

- (b) Refractive index of diamond = 2.42
 Refractive index of water = 1.33
 Refractive index of water w.r.t diamond

$$= \frac{1.33}{2.42} = 0.55$$

Note: As per questions, answer in 0.55 but in practice the value of refractive index of any material will always be greater than or equal to one ($\mu \geq 1$)

26. (a) Maxwell's Right-Hand Thumb Rule can be used to determine the direction of magnetic field lines around a current-carrying conductor.
 It states that, if the thumb of the right hand represents the direction of the current flow, the rest of the curled fingers determine the direction of the magnetic field around it. 1
- (b) Fleming's left hand rule is used to find the direction of force experienced by a current carrying straight conductor placed in a magnetic field which is perpendicular to it. Fleming's left-hand rule can be stated as stretching the forefinger, middle finger, and thumb of the right hand such that they are mutually perpendicular to each other. Here, the forefinger indicates the direction of the magnetic field; the middle finger indicates the direction of current in the conductor. 1

SECTION — C

27. Pulmonary circulation transports oxygen-poor blood from the right ventricle to the lungs, where blood picks up a new blood supply. Then it returns the oxygen-rich blood to the left atrium. 1
 Systemic circulation carries oxygenated blood from the left ventricle, through the arteries, to the capillaries in the tissues of the body. From the tissue capillaries, the deoxygenated blood returns

through a system of veins to the right atrium of the heart. 1

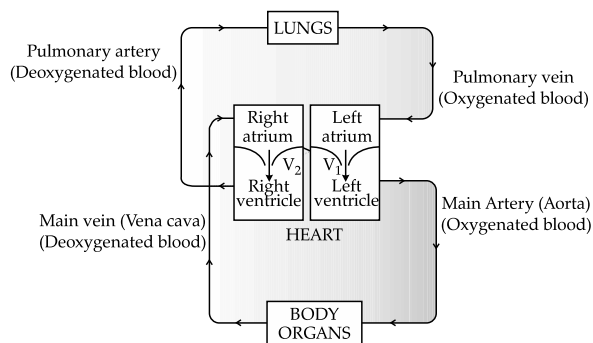

28. (a) (i) Substance X is calcium carbonate. $\frac{1}{2}$
Chemical formula: CaCO_3 $\frac{1}{2}$
 (ii) In the reaction between calcium carbonate and dilute hydrochloric acid (HCl), calcium chloride (CaCl_2), carbon dioxide (CO_2) and water (H_2O) are produced.

$$\text{CaCO}_3(\text{s}) + 2\text{HCl}(\text{aq}) \rightarrow \text{CaCl}_2(\text{aq}) + \text{H}_2\text{O}(\text{aq}) + \text{CO}_2(\text{g})$$
 1
 The carbon dioxide evolved reacts with limewater ($\text{Ca}(\text{OH})_2$) to form calcium carbonate and water.

$$\text{Ca}(\text{OH})_2(\text{s}) + \text{CO}_2(\text{g}) \rightarrow \text{CaCO}_3(\text{s}) + \text{H}_2\text{O}(\text{aq})$$
 1
 The production of calcium carbonate is responsible for the milky white colour. 1

OR

- (b) (i) Hydrogen gas 1
 (ii) On bringing a burning match stick near the mouth of the test tube, again a pop sound occurs. 2
 (iii) **Reaction with acid:**

$$\text{Zn}(\text{s}) + 2\text{HCl}(\text{aq}) \rightarrow \text{ZnCl}_2(\text{aq}) + \text{H}_2(\text{g})$$

Reaction with base:

$$2\text{NaOH}(\text{aq}) + \text{Zn}(\text{s}) \rightarrow \text{Na}_2\text{ZnO}_2(\text{aq}) + \text{H}_2(\text{g})$$
 $\frac{1}{2} + \frac{1}{2}$
29. (a) **Hormone:** Adrenaline 1
Functions:
- Increases the heart rate.
 - Increases blood pressure.
 - Expands the air passages of the lungs.
 - Enlarges the pupil in the eye. (Any two) 1+1

OR

- (b) (i) A - Sensory neuron $\frac{1}{2}$
 B - Relay neuron $\frac{1}{2}$
 C - Effector (Muscle in arm) $\frac{1}{2}$
 (ii) Function of part A- Sensory neuron carries impulses from the receptor to the CNS (spinal cord). $\frac{1}{2}$
Function of part C: An effector is a part of the body which can respond to a stimulus according to the instructions sent from the nervous system (spinal cord and brain). The effectors are mainly the muscles and glands of our body. $\frac{1}{2}$
 (iii) Reflex arc, have evolved in animals, in order to perform quick responses, as the thinking process of brain is not fast enough. $\frac{1}{2}$

30. (a) **Change in temperature:** When zinc reacts with sulphuric acid, the test tube in which the reaction is taking place will be hot, indicating that the temperature is rising during the reaction.

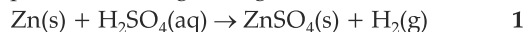

- (b) **Evolution of gas:** The chemical reaction between zinc and dilute sulphuric acid is characterized by the evolution of hydrogen gas. On bring a burning matchstick near the gas jar if it burns with a pop sound, the presence of hydrogen gas is confirmed.



- (c) **Change in colour:** The reaction between lead nitrate solution and potassium iodide solution. In this reaction colour changes from colourless to yellow.



31. Myopia may arise due to:

excessive curvature of the eye lens, or (ii) elongation of the eyeball. $\frac{1}{2} + \frac{1}{2}$

- (a) This defect can be corrected by using a concave lens of suitable power.

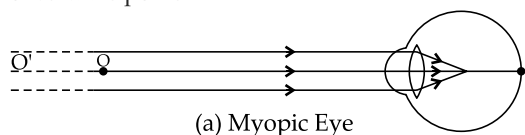

(a) Myopic Eye 1

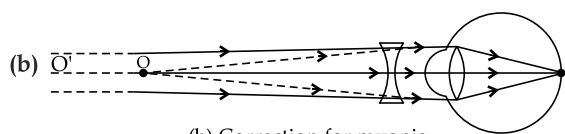

(b) Correction for myopia 1

32. A solenoid is a long coil containing a large number of close turns of copper wire wound on any insulator. 1

A solenoid acts as a magnet when a current is supplied through it. 1

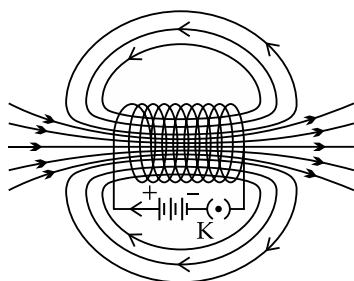

Field lines of the magnetic field through and around a current carrying solenoid 1

33. (a) (i) The autotrophs capture about 1% of the solar energy that falls on their leaves for the process of photosynthesis.

- (ii) According to "The 10% Rule", there is only 10% flow of energy from one trophic level to the next higher level so, only 10% energy will get transferred from autotrophs to the herbivores. $\frac{1}{2} + \frac{1}{2}$

- (b) **Trophic level:** The various steps in a food chain or ecological pyramid, at which the transfer of food (or

energy) takes place from one organism to another organism is known as trophic levels. 1

There is only 10% flow of energy from one trophic level to the next higher level. The loss of energy at each step is so large that very little usable energy remains after four or five trophic levels. Hence, only 4 to 5 trophic levels are present in each food chain. 1

SECTION — D

34. (a) (i) Compound A- Acetic acid/ CH_3COOH 1/2

Nature: Its nature is acidic. 1/2

Name of the functional group: COOH 1/2

Chemical equation:

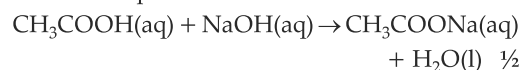

- (ii) (1) B – Ethanol ($\text{C}_2\text{H}_5\text{OH}$) 1/2

C – Ethyl acetate 1/2

- (2) **Role of acid:** It is a catalyst which will speed up the process and esterification will proceed speedily and complete on time. 1

- (3) **Chemical equation:**



Ethanol Acetic acid
or or
Ethyl alcohol Ethanoic acid



Ethyl ethanoate

or

Ethyl acetate 1

OR

- (b) (i) Ethyl alcohol is converted into Ethene by heating Ethyl alcohol ($\text{C}_2\text{H}_5\text{OH}$) in the presence of concentrated Sulphuric acid (H_2SO_4). 1

The chemical reaction is as follows:

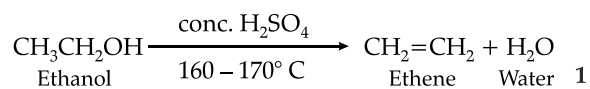

Electron dot structure of Ethene:

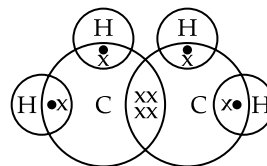

1

Role of Conc. H_2SO_4 : Concentrated sulphuric acid (conc. H_2SO_4) acts as a dehydrating agent in the conversion from ethanol to ethane. It helps in removing water molecule. 1

- (ii) **Hydrogenation:** The process in which unsaturated compounds reacts with hydrogen in the presence of nickel (as a catalyst) to form saturated compounds are called hydrogenation.

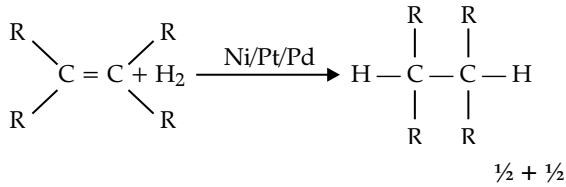

Role in industry: This reaction is commonly used in the hydrogenation of vegetable oils. Vegetable oils have long unsaturated carbon chains, which are converted into vegetable ghee i.e., saturated fatty acids. 1

35. (a) During reproduction, the information for inheritance of characteristics is passed on from the parents to the offsprings in the form of DNA. DNA in the cell nucleus carry the genetic information. Hence DNA copying is the basic event in reproduction. If the information during the DNA copying is changed, different proteins will be made. Different proteins will eventually lead to altered body designs. 1
- (b) The process of fertilisation is the fusion of both male and female gametes. If pollination does not occur it means that the male gamete is not available, hence fertilization cannot take place. 1
- (c) Regeneration and fragmentation is only possible when the entire body part is made up of similar kind of cells. All multicellular organisms cannot give rise to new individuals through fragmentation or regeneration because the complex multicellular organisms have organ system level organization. The tissues in these organisms are highly differentiated to perform specialized functions and cannot regenerate a new individual.
- (d) Vegetative propagation is practiced for growing some types of plants because of following advantages:
- It is used to grow a plant in which viable seeds are not formed or very few seeds are produced such as orange, banana, pineapple.
 - It helps to introduce plants in new areas where the seed germination fails to produce mature plant due to change in environmental factors and the soil.
 - It is more rapid, easier and cheaper method.
 - By this method a good quality of a race or variety can be preserved. (Any two) 1
- (e) Gametes of sexually-reproducing animals have half the number of chromosomes as that of the parents. During fertilisation, when two gametes i.e. male and female gametes fuse, the offspring produced will have the same amount of DNA or the same number of chromosomes as that of the parent. 1
36. (a) (i) Resistance is defined as the property of a conductor to resist the flow of charges through it. The resistance of a conductor is numerically given as the ratio of the potential difference

across its length to the current flowing through it. 1

Its SI unit is ohm The resistance of a conductor is said to be 1 ohm if a current of 1 ampere flows through it when the potential difference across it is 1 volt. 1

(b) (ii) **Resistance of a conductor depends on:**

(1) Length of the conductor.

(2) Area of cross section of the conductor. $\frac{1}{2} + \frac{1}{2}$

(iii) (1) Resistance is directly proportional to the length. Hence, if length is doubled, resistance is also doubled. 1

(2) The resistance of a wire is inversely proportional to the area of cross-section the wire. Thus, if the radius is doubled, the area increases four times and hence the resistance becomes one-fourth. 1

OR

(b) Case (1):

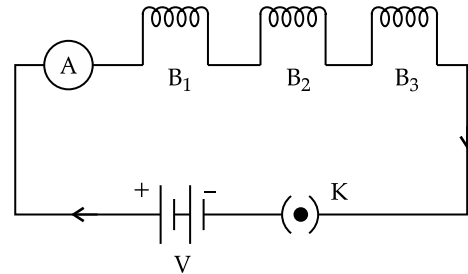

Case (2):

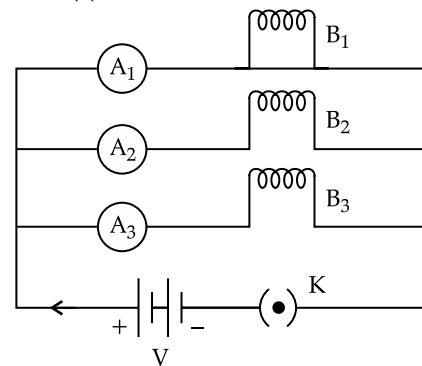

$\frac{1}{2} + \frac{1}{2}$

(i) Let us assume that resistance of each bulb is R and the source of voltage is V.

Case (1) Series combination

$$R_{equ} = R + R + R = 3R$$

$$\text{Current in each bulb (I)} = \frac{V}{3R}$$

Case (2) Parallel combination

$$\text{Net current (I}_{equ}) = \frac{3V}{R}$$

Current will get equally divided in three bulbs (I)

$$= \frac{I_{equ}}{3} = \frac{3V}{R \times 3} = \frac{V}{R}$$

As, Power (P) = $\frac{V^2}{R}$ therefore P is inversely

proportional to R.

Hence, bulbs in case (2) will glow with great brightness as because power is 3 times more than that in case (1) **1+1**

- (ii) In case (1), if one bulb gets fused, rest of bulbs will not glow because in series circuit the voltage across the circuit is the sum of the voltages across each bulb.

But in case (2), parallel combination, the voltage across each bulb is the same so, all other bulbs will glow as voltage eruption in the fused bulb does not affect the voltage of other bulbs. **1+1**

SECTION — E

37. (a) Electrolytic reduction

The metal is likely to be Sodium (Na). It has very much affinity to oxygen. So, reducing agents like carbon and aluminum can't be used. **1**

- (b) Because aluminium has greater affinity for oxygen than for carbon, therefore carbon cannot reduce alumina (Al_2O_3) to aluminium. **1**

- (c) Cinnabar (HgS-mercury (II) sulphide or mercury sulphide) is an ore of mercury. It is heated in air to give mercuric oxide (HgO). Mercuric oxide is further heated to get mercury. The reactions involved are,

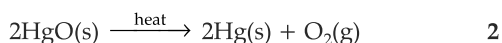
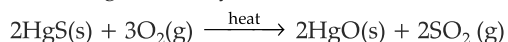

OR

Calcination is defined as the process of converting ore into an oxide by heating it strongly. The ore is heated below its melting point either in absence of air or in limited supply.

e.g., $\text{ZnCO}_3 \rightarrow \text{ZnO} + \text{CO}_2$

Roasting is a process of metallurgy where ore is converted into its oxide by heating it below its melting point in the presence of excess air.

An example of roasting is when Zinc sulphide is converted into zinc oxide.

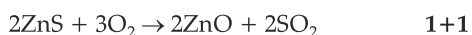

38. (a) Zygote is formed due to the fusion of male and female gametes. Gametes are haploid cells. Thus fusion of two haploid cells results in the formation of a diploid cell. Therefore zygote is a diploid cell with 46 chromosomes. **1**

- (b) In a few reptiles, the temperature at which fertilised eggs are kept determines whether the animals developing in eggs will be male or female. By this we can say that some animals rely entirely on environmental cues for sex determination. **1**

- (c) There is equal chance of fusion of either X or Y chromosome with the egg. So, we can say that the sex of new born child is a matter of chance and none of the parent is responsible for it.

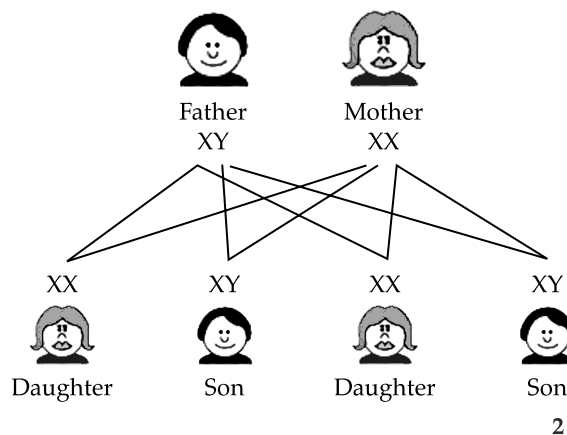

Human females are homomorphic. They have two sex chromosomes that are identical. One X-chromosome enters each gamete during meiosis at the time of gamete formation. So, all gametes have an X-chromosome. **2**

39. (a) In case I, image is formed between F and C. It is real, inverted, and smaller in size. **1**

- (b) In Case II, since, the object is placed at centre of curvature. **1**

- (c) Dentists use concave mirrors to see teeth and other areas in the mouth. This is because a concave mirror forms a virtual, erect and enlarged image when the object is placed within focus. **2**

OR

In case III can be used as having mirror because, when object is placed between P and F, we get virtual, erect and magnified image.

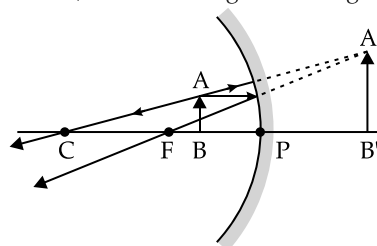

2

SECTION — A

1. Option (b) is correct. **1**

Explanation: The balanced equation is:

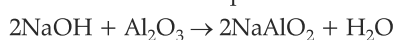

2. Option (b) is correct. **1**

Explanation: When basic solutions such as sodium hydroxide are added to turmeric, the solution turns pinkish-red. If the same basic solution is poured on

universal indicator, its colour would change to blue. The pH of the solution will range from 8-11. The universal indicator will give violet or purple color if the solution is a strong base.

5. Option (b) is correct. 1

Explanation: Trypsin breaks down proteins into smaller peptides in the duodenum of the small intestine. Pepsin is a stomach enzyme that serves to digest proteins found in ingested food. Lipase is an enzyme the body uses to break down fats in food so they can be absorbed in the intestines. Amylase helps your body break down starches.

7. Option (d) is correct. 1

Explanation: The concave mirror has a radius of curvature = -60.0 cm

$$\text{So, Focal length } (f) = \frac{-60}{2} = -30 \text{ cm}$$

(-ve is taken because the focus of the mirror is behind the pole)

Given, Magnification = +2.0

$$\text{Since, } \frac{1}{v} + \frac{1}{u} = \frac{1}{f} \quad \dots(1)$$

Here, v is image distance, u is object distance and f is focal length.

$$\text{Magnification formula} = -\frac{v}{u} \quad \dots(2)$$

Putting the value of magnification, we get,

$$-\frac{v}{u} = 2$$

$$v = -2u$$

Now, putting the value of v and f in equation (1) we get,

$$\frac{1}{-2u} + \frac{1}{u} = \frac{1}{-30}$$

$$\frac{-1}{2u} + \frac{2}{2u} = \frac{1}{-30}$$

$$\frac{1}{2u} = \frac{1}{-30} \quad 1$$

or $u = -15 \text{ cm}$

13. Option (c) is correct. 1

Explanation: The formation of rainbow involves all three phenomenon: Refraction, dispersion, and total internal reflection. The sunlight shines on a water droplet. As the light passes into the raindrop the light bends, or refracts. Due to slow down of light, white light gets dispersed into seven colours. Then total internal reflection happens on the other end of the drop.

18. Option (c) is correct. 1

Explanation: An ecosystem is a unit of biosphere in which biotic and abiotic components interact with each other. Biotic components depend on abiotic factors for survival.

SECTION — B

21. (a) The metal nitrate (A) is Lead nitrate $\text{Pb}(\text{NO}_3)_2$ $\frac{1}{2}$

On heating it produces Lead oxide, Nitrogen dioxide (B), and oxygen gas. $\frac{1}{2}$

(b) In first reaction, lead nitrate is decomposed to give lead oxide, nitrogen dioxide, and oxygen gas. This reaction is a decomposition reaction, where one reactant breaks down into two or more products.

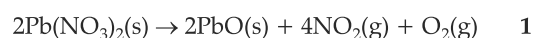

Aqueous lead nitrate on reaction with potassium iodide forms lead iodide and potassium nitrate.

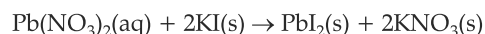

Here, lead nitrate is reacting with potassium iodide to form lead iodide and potassium nitrate, an exchange of ions takes place. Hence, it is a double displacement reaction where the exchange of ions between the compounds takes place. 1

24. To get an equivalent resistance of 8Ω , we have to use both parallel and series connection in the circuit. First, the two resistors are connected in parallel to obtain a combined resistance of 2Ω and then the combined resistance is connected in series with the third resistor to give a total resistance of 8Ω .

That is, for the two resistors in parallel the resistance is given as:

$$\frac{1}{R_p} = \frac{1}{4} + \frac{1}{4} = \frac{1}{2} \Omega$$

$$R_p = 2 \Omega$$

Now, R_p and 6Ω is added in series as

$$R_s = 2 + 6 = 8 \Omega.$$

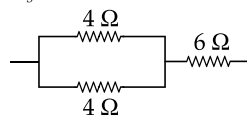

2

SECTION — C

29. (a) Tendrils are sensitive to touch. When they come in contact with any support, the part of the tendril in contact with the object does not grow as rapidly as the part of the tendril away from the object. This causes the tendril to circle around the object and thus cling to it. 2

Auxin is the hormone that promotes the growth of tendril around a support as it is synthesized in the tip of the shoot and stimulates the growth of the cells on the opposite side which causes coiling of the tendril around the support. 1

OR

(b) **Geotropism:** It is the movement of plant parts in response to the direction of gravity. The growth of plant roots is an example of geotropism as it grows towards the direction of gravity. 1

Hydrotropism: It is the movement of a plant towards the water. 1

Example: The plant roots always move towards water hence shows positive hydrotropism. 1

Chemotropism: It is the movement of plants in response to a chemical stimulus. A classic example of this type of movement is the growth of the pollen tube towards the ovule, during fertilization, in a flower. 1

31. (a) The brown colour metal is copper (Cu) and black coloured substance is Copper oxide (CuO). $\frac{1}{2} + \frac{1}{2}$

(b) (i) When Cu metal is heated in an open china dish then Cu metal gets oxidized.



(ii) When hydrogen gas is passed over the black substance then CuO gets reduced.

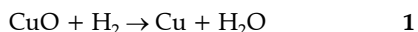

33. The food chain begins with the producers or the autotrophs followed by the primary (herbivores) and secondary consumers (carnivores) and ends with the decomposers. In the given question the food chain is represented as:

Plants → Mice → Snakes → Hawks

So, with respect to the food chain in the given question, the maximum accumulation of the toxins is found in Hawk as it occupies the highest trophic level. 1

If any harmful chemical or toxin is consumed by the organism and it enters the food chain then it is passed on from one trophic level to the other. This is known as biomagnification. 1

Biomagnification is the process by which the toxins are built up within organisms and the maximum build up takes place in the larger species or the

animals occupying the highest trophic level in the food chain. This is due to larger animals eating up smaller ones. 1

SECTION — D

34. (i) Isomers are compounds that have same empirical formula but differ in the arrangement of atoms in the compounds. 1

Isomers of $\text{C}_3\text{H}_6\text{O}$

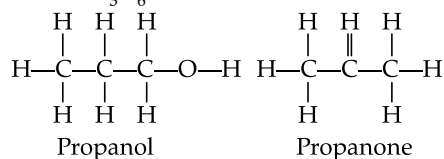

(ii) Soap is a sodium salt or potassium salt of long chain fatty acids having cleansing action in water. They are used as cleansing agents to remove dirt, oil from the skin and clothes. 1 Soaps are the sodium salts of carboxylic acids in long chains whereas sodium salts of long-chain benzene sulphonic acids are detergents. 1

Hard water contains calcium and magnesium ions. When soaps are dissolved in hard water, these ions displace sodium or potassium from their salts and form insoluble calcium or magnesium salts of fatty acids. These insoluble salts separate as scum. Hence, hard water does not produce lather with soap immediately. 1

OR

(b) (i) A homologous series is a series of organic compounds that belongs to the same family (i.e., possesses the same functional group) and show similar chemical properties. The members of this series are called homologous, as they differ from each other by the number of CH_2 . General formula of alkynes are: $\text{C}_n\text{H}_{2n-2}$ 1

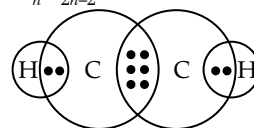

Electron dot structure of ethyne:

(ii) A functional group is an atom or a group of atoms that is bonded to a carbon chain and defines the chemical property of the organic compound. 1

Alcohols: OH functional group $\frac{1}{2}$

Carboxylic acid: COOH functional group $\frac{1}{2}$

SECTION — A

4. **Option (b) is correct.** 1

Explanation: Metals like zinc react with acid to give hydrogen gas and form metal salts.

7. **Option (b) is correct.** 1

Explanation: Inside a bulb there generally is a concave reflector. For a concave mirror, when an object is placed at its focus, after reflection from the mirror, it reflects a parallel beam of light that goes to infinity. Hence, in torches, searchlights, and headlights of vehicles, the bulb is placed very near to the focus of the reflector.

10. Option (b) is correct. 1

Explanation: The correct matching is:

A. Physical environment	(iii) Abiotic components
B. Exposure to UV radiation	(iv) Skin cancer
C. Chlorofluoro carbon compounds	(i) Ozone layer depletion
D. Decomposers	(ii) Bacteria and fungi

11. Option (d) is correct. 1

Explanation: Hyphae are the fine thread-like structures of the fungi that are spread on the whole surface of a slice of bread.

12. Option (b) is correct. 1

Explanation: The relaxation or contraction of ciliary muscles changes the curvature of the eye lens. The change in curvature of the eye lens changes the focal length of the eyes. Hence, the change in focal length of an eye lens is caused by the action of ciliary muscles.

19. Option (a) is correct. 1

Explanation: The testes is located outside the abdominal cavity because sperm formation requires a temperature lower than the body temperature. It is because scrotum has a temperature 1-3 degree Celsius lower than the normal body temperature, which is essential for the production of sperm or male gametes.

SECTION — B

22. A nerve impulse is generated when the stimulus is strong. This stimulus triggers the electrical and chemical changes in the neuron. 1

(i) Dendrites are the part of neurons where information is acquired. It receives impulses and transmits impulses toward the cell body. ½

(ii) Axon is the part of the neuron through which information travels as an electric impulse. It helps in transmitting impulses away from the cell body. ½

OR

Feedback mechanism is the mechanism in our body to maintain the hormonal levels in the body in desirable amount. An increase or decrease in the hormonal level in our body triggers the feedback mechanism. 1

For e.g., The increase in the blood sugar level stimulates the secretion of insulin so that the sugar level is maintained. If the blood sugar level falls below normal, then it stimulates the secretion of glucagon. Glucagon stimulates the breakdown of glycogen to glucose, and thus, the normal sugar level is maintained. 1

26. The diagram of the pattern of field lines is as follows:

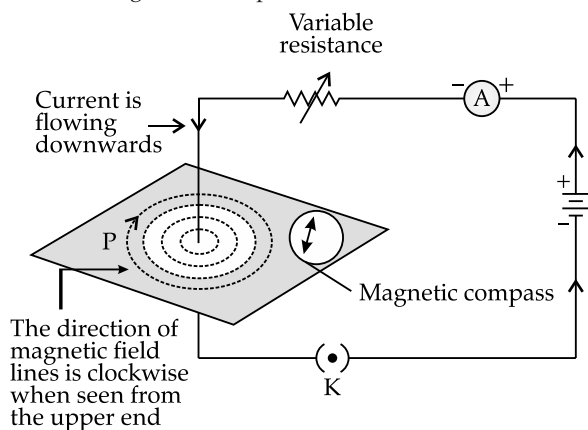

The strength of the magnetic field is inversely proportional to the distance from the origin. The strength of the magnetic field will decrease as the place where the magnetic field is to be calculated is moved away from the straight conductor. 1

28. (a) (i) Similarity between acid and base:

Both acids and bases are electrolytes, which mean that they're good conductors of electricity. Acids and bases both produce ions in water solution. Acids release hydrogen ions (H^+) whereas Bases release hydroxide ions (OH^-). The process of mixing acid or a base in water is an exothermic one. 1

(ii) Plaster of Paris. Its formula is $CaSO_4 \cdot \frac{1}{2} H_2O$. 1

Plaster of Paris is prepared by heating gypsum at 373K.

The chemical equation is:



OR

(b) (i) The chemical name and the formula of the compound that makes up the tooth enamel is Calcium hydroxyapatite – $Ca_{10}(PO_4)_6(OH)_2$ 1

(ii) If pH of mouth falls below 5.5, the enamel gets corroded. 1

Toothpastes which are generally basic and used for cleaning the teeth can neutralize the excess acid and prevent tooth decay. 1

31. Myopia is that defect of human eye by virtue of which it can see clearly the objects lying at short distance from it. But the far off objects cannot be seen clearly by the myopic eye.

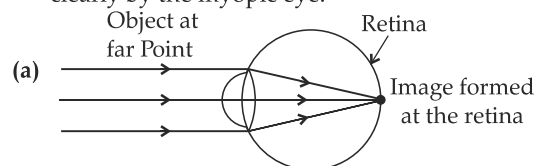

(b) It is caused by:

(i) Excessive curvature of the eye lens

(ii) Elongation of the eyeball

½ + ½

- (c) A myopic eye can be cured by using a concave lens of suitable power or focal length.

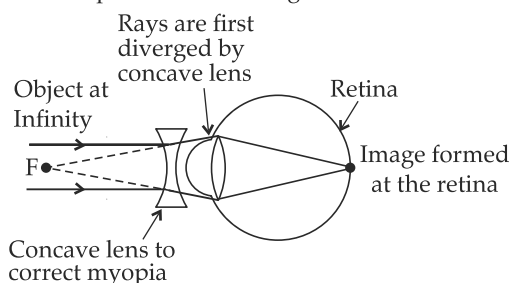

33. (a) (i) When Silver Chloride (AgCl) is exposed to sunlight it changes from White to Gray. 1

Reason: When Silver Chloride is exposed to sunlight, it undergoes photochemical decomposition to produce Silver and Chlorine.



- (b) When a piece of zinc is dropped in a copper sulphate solution, the colour of the solution fades from blue to colourless.

Reason: Zinc is more reactive than iron. Therefore, when zinc is added to the solution of iron sulphate, the colour of iron sulphate solution changes and a grey precipitate of iron and a colourless solution of zinc sulphate is formed.



- (c) Upon strongly heating copper powder in the presence of oxygen, it changes its colour from brown to black.

Reason: When copper powder is strongly heated in the presence of oxygen, then copper reacts with oxygen present in the air to form copper oxide.

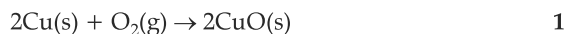

SECTION — D

35. (a) The two types of pollination are self pollination and cross pollination. ½

(i) **Self pollination:** When the pollen grains from the stamens of a flower fall on the stigma of the same flower, then self pollination occurs.

(ii) **Cross pollination:** When pollen grains from the stamens of a flower fall on the stigma of another flower, then cross pollination occurs. ½ + ½

- (b) Post fertilisation changes that occur in the ovary of a flower are:

(i) The fertilized ovule forms a seed.

(ii) The seed contains an embryo, enclosed in a protective covering, called the seed coat.

(iii) As the seed grows further, other floral parts wither and fall off.

(iv) This leads to the growth of the ovary, which enlarges and ripens to become a fruit with a thick wall called the pericarp. ½ × 4 = 2

- (c) (i) The part labeled as A is Plumule, which give rise to future shoot.

(ii) The part labeled as B is radical, which give rise to future root.

(iii) The part labeled as C is cotyledon, which stores food. 1½

